



LAGOON



USER GUIDE





# WELCOME ABOARD

We share a common passion for the sea; we, LAGOON, as catamaran builders and you who want to live your passion on the seven seas.

We are delighted to welcome you to the family of LAGOON catamaran owners and we congratulate you on it.

This instruction guide is intended to help you to enjoy your boat in comfort and safety. It includes the boat specifications, the equipment provided or installed, the systems on board and tips on her use and maintenance. We advise you to read this guide carefully before setting sail in order to take the greatest advantage of your sailing.

Our network of LAGOON official retailers is entirely at your disposal in order to help you discovering your boat. They will be the most able to do the maintenance on your boat.







 51

# REJOIGNEZ LE CLUB LAGOON ! JOIN THE CLUB LAGOON!

Vous venez d'acquérir un catamaran Lagoon! Saviez-vous qu'un club de propriétaires existait? En tant que propriétaire Lagoon, vous bénéficiez d'un accès exclusif à ce club.

## POURQUOI LE CLUB LAGOON ?

Il s'inscrit dans la logique de la *Lagoon Attitude* qui nous est chère : entretenir des relations simples et amicales avec nos clients, leur proposer des rendez-vous privilégiés, aller à leur rencontre. Avec le *Club Lagoon*, nous voulons concrétiser cet état d'esprit en vous faisant bénéficier de certains avantages.

## QUELS AVANTAGES POUR LES MEMBRES DU CLUB LAGOON ?

En tant que membre du *Club Lagoon*, vous avez accès au site privé [www.club-lagoon.fr](http://www.club-lagoon.fr) : des informations sur le chantier, nos catamarans et nos événements, des fiches techniques, des invitations aux salons nautiques, une boutique privée, et des offres exclusives de nos partenaires (à voir sur le site !).

**L'adhésion au *Club Lagoon* est simple et gratuite. Nous serons très heureux de vous y accueillir, alors n'hésitez plus, rendez-vous sur notre site pour vous inscrire.**

You have just purchased a Lagoon catamaran! Did you know that an owner club exists? As Lagoon owner, you get an exclusive access to this club.

## WHY JOIN CLUB LAGOON?

The Club reflects the *Lagoon Attitude* that we value so highly: in other words, our desire to develop warm, open relations with our customers, organise special events for you and meet you in person. With *Club Lagoon*, we wish to follow through with this way of thinking by giving you access to some specific benefits.

## WHAT BENEFITS DO CLUB LAGOON MEMBERS ENJOY?

As a member of *Club Lagoon*, you can access the private website [www.club-lagoon.fr](http://www.club-lagoon.fr): here you will find exclusive information about the shipyard, our catamarans and our events, technical documents, invitations to boat shows, an exclusive boutique and special offers from our partners (you can see them on the website).

***Club Lagoon* membership is free and it couldn't be simpler to join. We look forward to welcoming you to the Club, so go to our website to register.**



[www.club-lagoon.fr](http://www.club-lagoon.fr)

**Club**  
Lagoon

# PREAMBLE

■ This user guide is a tool that will enable you to get to know your boat and apprehend the use of the components that are necessary for running her. Some of the equipments mentioned in this guide are optional fittings.

## ■ A WAY TO MAKE THE MOST OF THIS USER GUIDE

In order to facilitate understanding, this guide offers two complementary levels of reading, including a first visual approach to the topics covered, supplemented by explanations in editorial or schematic form.

■ The various warnings used throughout this guide are as follows:

### ***RECOMMENDATION***

A piece of advice concerning the appropriate actions or manoeuvres most suited to the planned action.

### ***CAUTION***

Draws your attention to dangerous ways of doing things that may cause injuries to people or damages to the boat or her components.

### ***DANGER***

Warns you about the existence of a hazard that may have serious or fatal consequences if the appropriate precautions are not taken.

■ Before setting sail, please read the owner's manual (CE standard manual) delivered with your boat and please follow the instructions.



# SUMMARY

1. BEFORE GETTING UNDER WAY	Page 07	5. LIFE ON BOARD - LIVING SPACES	Page 49	9. SAFETY ABOARD	Page 93
1.1 Going on board		5.1 Saloon		9.1 Prevention	
1.2 Switching on the 12 V supply		5.2 Televisions - Hifi		9.2 Safety equipment	
1.3 Control touch screen - Presentation		5.3 Windows		9.3 Gas system	
1.4 Switching on 110 V - 220 V supply		5.4 Washer-dryer		9.4 Fire prevention	
		5.5 Air conditioning		9.5 Bilge pumping	
2. GETTING UNDER WAY - SAILING	Page 17	6. LIFE ON BOARD - GALLEY	Page 57	10. MAINTENANCE	Page 105
2.1 Helm station		6.1 Fresh water		10.1 Construction	
2.2 Chart table		6.2 Watermaker		10.2 Careening	
2.3 Engine start procedure		6.3 Ice maker		10.3 Deck equipment	
2.4 Sailing		6.4 Dishwasher		10.4 Propellers and anodes	
2.5 Sails		6.5 Refrigerators - freezer		10.5 Winter storage	
2.6 Electronics		6.6 Gas oven and hobs		10.6 Handling	
		6.7 Microwave oven		10.7 Maintenance schedule	
		6.8 Cockpit plancha			
3. ANCHORING - MOORING	Page 31	7. LIFE ON BOARD - PRIVATE SPACES	Page 69	11. GENERAL SPECIFICATIONS	Page 115
3.1 Bow thruster		7.1 Head compartments		11.1 Technical specifications	
3.2 Anchoring		7.2 Toilets		11.2 Engine layout	
3.3 Davits				11.3 Plumbing layout	
3.4 Tenderlift				11.4 Electricity layout	
				11.5 Overview of 12 V elements	
				11.6 Overview of 110 V / 220 V elements	
				11.7 Control touch screen - Function overview	
4. LIFE ON BOARD - EXTERIOR FEATURES	Page 41	8. ENERGY - ENGINE	Page 77	12. MEMORANDUM	Page 133
4.1 Stern cockpit		8.1 Batteries		12.1 Your boat	
4.2 Fore cockpit		8.2 Shore power sockets		12.2 Personal notes	
4.3 Flying bridge		8.3 Inverters			
4.4 Swim area		8.4 Generator			
		8.5 Electricity - Annexes			
		8.6 Motorization			



# BEFORE GETTING UNDER WAY

---

1

- 1.1 Going on board**
- 1.2 Switching on the 12 V supply**
- 1.3 Control touch screen - Presentation**
- 1.4 Switching on 110 V - 220 V supply**

## 1.1 Going on board

ACCESS BY THE AFT TRANSOMS



SLIDING BAY WINDOWS OF THE DOOR



### ■ BOARDING

The boat is equipped with opening chains on the port and starboard transom skirts.

#### **CAUTION**

For safety, close the aft chains before sailing.

The boat may optionally be fitted with a carbon folding gangway.  
Remove, store and secure the gangway when sailing.

#### **CAUTION**

Do not use the gangway as a diving platform.

## 1.1 Going on board

**INTERIOR LOCK  
OF THE DOOR**



**COCKPIT STAIRS**



**ACCESS TO THE FLYING BRIDGE**



### ■ ENTRANCE DOORS

The bay window consists of four sections, two outer fixed and two sliding. Sliding doors are locked in three different positions: closed, open on one side or open on both sides.

Latches on the door jambs allow locking from inside the saloon.

#### **RECOMMENDATION**

When sailing, block the sliding doors by locking them.

### ■ ACCESS TO THE FLYING BRIDGE

The flying bridge helm can be reached from the bridge by stairs to starboard and port.

#### **RECOMMENDATION**

Beware of the boat movements when using the flying bridge stairs while sailing.

## 1.2 Switching on the 12 V supply

**GENERAL CIRCUIT BREAKER  
STARBOARD ENGINE COMPARTMENT**



### ■ SWITCHING ON THE 12 V CIRCUIT

The 12 V circuit is switched on at the manual cut-out (position ON) located in the starboard engine compartment.

### **CAUTION**

It is absolutely essential to set the cut-outs to OFF if the boat is left unattended for a long time (the battery bank may be completely deteriorated).

**ELECTRICAL PANELS**



### ■ ELECTRICAL PANELS

There are various electrical panels located in the companionway to the starboard hull. They include a 12 V electric panel, a multi-function touchscreen display, 110 V / 220 V source selectors together with a generator control.

## 1.2 Switching on the 12 V supply

### 1 12 V ELECTRICAL CABINET

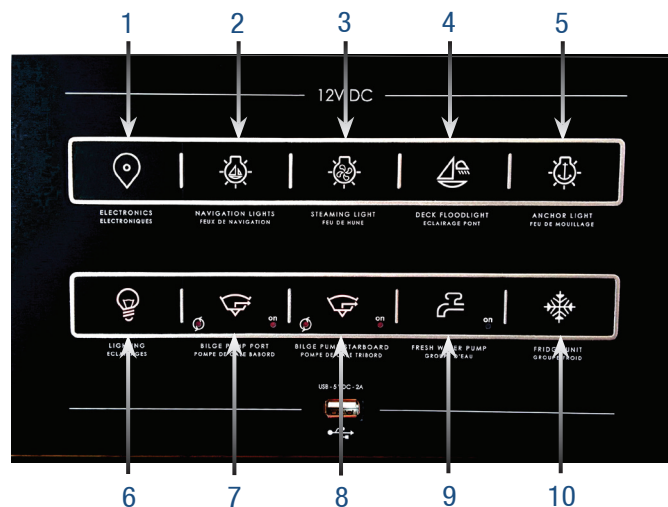

- 1 - Switching on the electronics.
- 2 - Navigation lights.
- 3 - Steaming light.
- 4 - Deck lighting.
- 5 - Anchor lights.
- 6 - Interior Lighting.
- 7 - Port bilge pump.
- 8 - Starboard bilge pump.
- 9 - Water unit.
- 10 - Cooling unit.

### 2 Touch screen

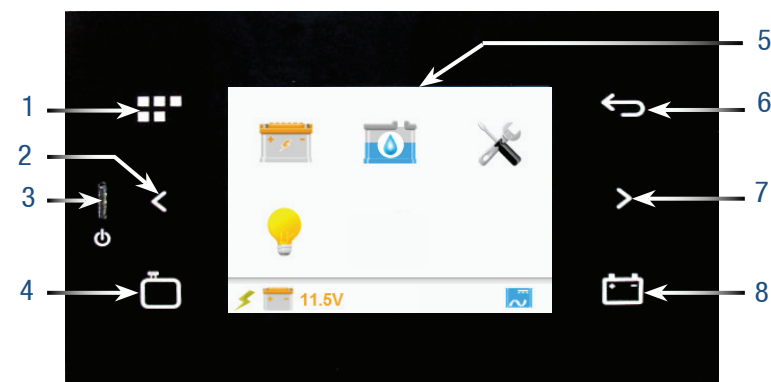

- 1 - Main menu.
- 2 - Navigation previous page.
- 3 - Control touch screen start / stop.
- 4 - Direct access to gauges menu for freshwater, fuel and grey water (option).
- 5 - Touch screen.
- 6 - Return to previous page.
- 7 - Navigation next page.
- 8 - Direct access batteries charge / voltage menu.

## 1.3 Control touch screen - Presentation

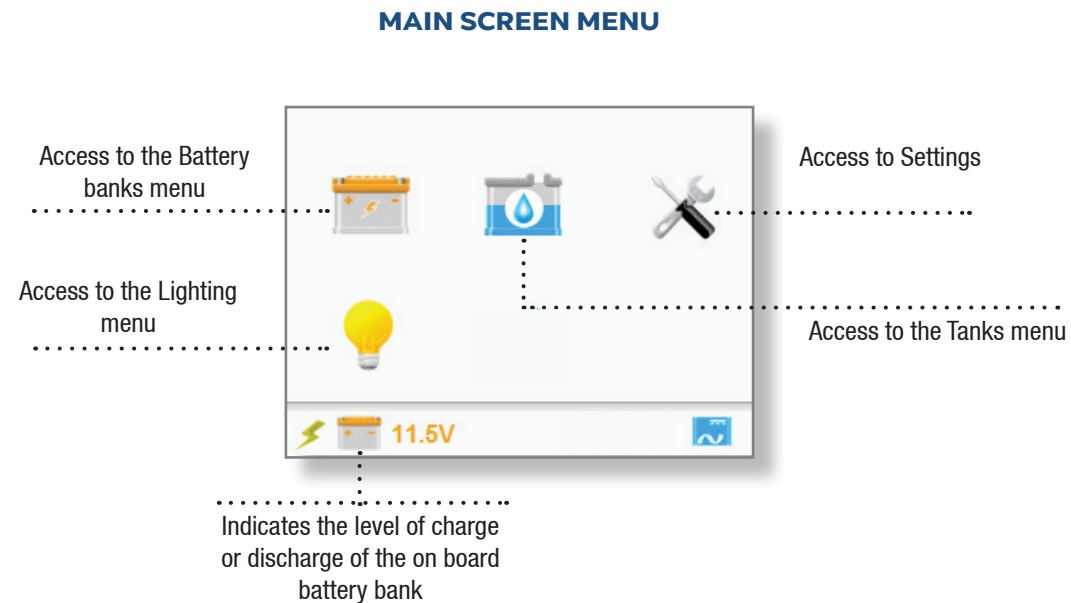

### ■ PRESENTATION OF THE CONTROL TOUCH SCREEN

The control touch screen was designed to pilot all the lighting on board, zone by zone. Refer to the following page for more details.

It monitors the charge and voltage levels of the battery banks.  
See pages 78 and 130 for more details.

It gives access to the fresh water, fuel and grey water (option) tank gauges.  
See pages 60, 90 and 71 for more details.

### ■ CONTROL TOUCH SCREEN FUNCTIONS

In the starboard engine compartment:

- Switch on the boat's 12 V circuit.

In the starboard hull companionway:

- Switch on the control touch screen using the power switch.
- According to needs, choose Main Menu (access to all functions managed by the screen), direct access Tanks or direct access Batteries.

Use the touch screen to navigate to the sub menus.

## 1.3 Control touch screen - Presentation

### LIGHTING ZONE SELECTION

### MENU BY ZONE (EXAMPLE)

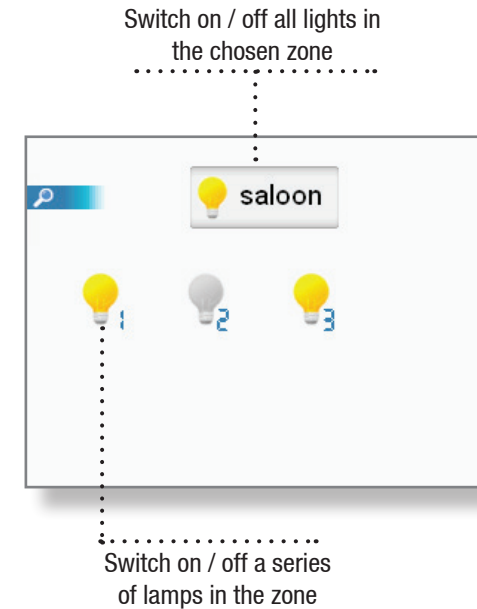
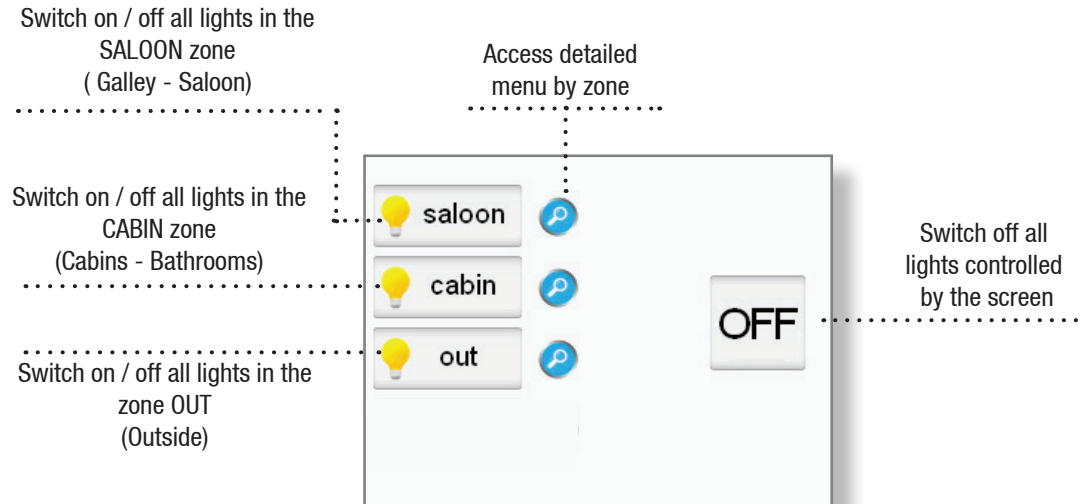

#### ■ ON-BOARD LIGHTING MANAGEMENT

After switching on the on-board 12 V circuit and the control touch screen:

- Use the touch screen to select the Lighting Menu icon.
- Move to the Lighting zone sub menus and select the areas of the boat to be lit.

Turn on the lights using the switches in the desired zone.  
Note: pressing on the SALOON icon turns off all zones in the Saloon area.

## 1.4 Switching on 110 V - 220 V supply

**SELECTION PANELS FOR  
110 V - 220 V POWER SUPPLY**



The boat is equipped with elements operating at 110 V - 220 V.  
It is possible to obtain 110 V - 220 V by three different means depending on the equipment concerned and the location of the boat:

- Moored using shore supplied power.
- Anchored using the generator or inverter.

To connect the shore power supply, generator and inverter, please refer to the ENERGY - ENGINE chapter.

**CIRCUIT BREAKERS  
ELECTRIC CONSUMERS**



■ CHECKING OF THE 110 V - 220 V CONSUMING APPLIANCES  
**SELECTION PANEL (left in the companionway to the starboard hull):**  
This cabinet has selector switches to choose the power supply source for the various 220 V electric consumer appliances on board.

**LEFT SELECTOR:**

- allows the use of devices using 110 V - 220 V from the generator, shore or inverter.

**RIGHT SELECTOR:**

- allows the use of air conditioning using 110 V - 220 V from the generator or the shore.

## 1.4 Switching on 110 V - 220 V supply

### • USE OF THE 110 V - 220 V POWERED APPLIANCES TO SWITCH ON THE APPLIANCES

In order to be able to use 110 V - 220 V powered appliances (watermaker, etc), first:

- Ensure that the circuit breakers are OFF on the corresponding 110 V - 220 V protection panel.
- Switch on the 110 V - 220 V source (start the generator or connect the shore power socket).
- Select this source from the selection panel to power the panel or operate the inverter for electrical sockets.

- Switch on the circuit breakers of the elements to be used on the 110 V - 220 V circuit breaker panel.

Then switch on the appliance using its own controls.

To start 110 V - 220 V appliances using the generator, wait for 10 to 15 seconds between the stop of each new component (in order to allow the generator to become stabilized and to be able to provide the necessary power for starting).

### • TO STOP THE 110 V - 220 V POWERED APPLIANCES

To stop 110 V - 220 V powered appliances (watermaker, etc) first:

- Stop the appliance with its own controls.

To stop 110 V - 220 V appliances using the generator, wait for 10 to 15 seconds between the stop of each new component (in order to allow the generator to become stabilized).

- Turn off turn off the automatic breaker of the appliance that is used on the circuit breaker panel.

- Turn the 110 V - 220 V source selector OFF (generator or shore power) or turn off the inverter.

### **RECOMMENDATION**

Check the battery charge during use of the inverter.

### **CAUTION**

Before you turn the 110 V - 220 V source selector to OFF, make sure no other appliance is working (danger of an electric arc that would destroy the changeover switch and risk of damaging the generator).



# GETTING UNDER WAY - SAILING

---

# 2

- 2.1 Helm station**
- 2.2 Chart table**
- 2.3 Engine start procedure**
- 2.4 Sailing**
- 2.5 Sails**
- 2.6 Electronics**

## 2.1 Helm station

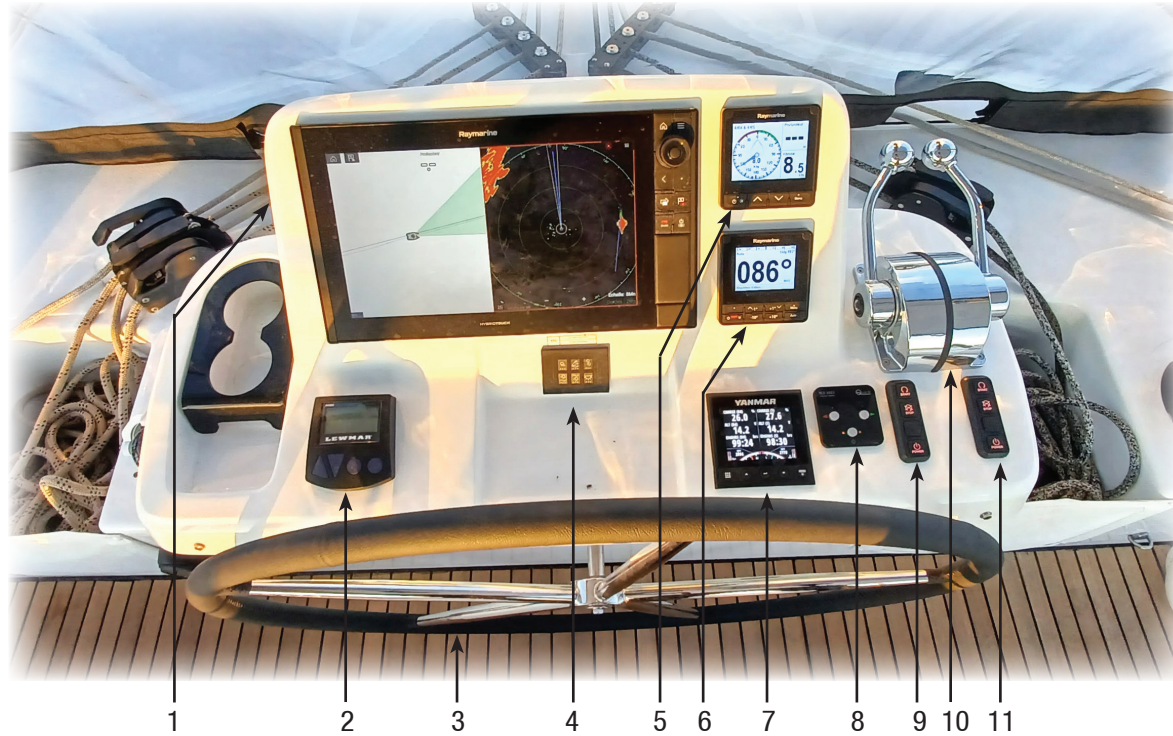

- 1 - 16" screen for electronics (option).
- 2 - Chain counter (option).
- 3 - Steering wheel.
- 4 - 6-key console.
- 5 - Screen / repeater for electronics (option).
- 6 - Screen / repeater for electronics (option).

- 7 - Engine screen (option).
- 8 - Bow thruster control (option).
- 9 - Port engine start console.
- 10 - Engine controls.
- 11 - Starboard engine start console.

5 - 6-key console.

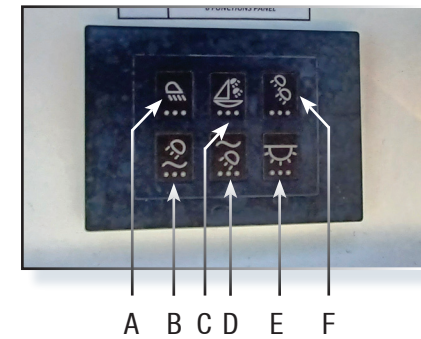

- A - Lighting bimini.
- B - Aft beam spotlights.
- C - Deck searchlight.
- D - Underwater spots
- E - Cockpit lighting.
- F - Courtesy lights.

## 2.2 Chart table



### CHART TABLE

The boat can be optionally equipped with a chart table console and screens for electronics.

Certain fuses are located behind the hatch under the saloon television panel, next to the chart table (ref. 1).

The upper part of the companionway to the starboard hull and underneath the chart table houses the 110 V / 220 V electric consumer circuit breakers (item 2).

The cabinet lower part contains the inverter and its circuit breaker (item 3).

## 2.3 Engine start procedure

FUEL TANK



ENGINE START CONTROLS



CIRCUIT BREAKER FOR  
COUPLING  
+ PORT SIDE ENGINE



### ■ STARTING

Before starting the engines:

- Check that the fuel valves are open (under the berths of the aft cabins, on the starboard and port side tanks).
- Open the valves of the engine cooling system (in the port and starboard engine compartments).
- Switch on the electric system turning their engine cutouts to ON (in port and starboard engine compartments).

After having checked that the inverter controls are set on Neutral, turn on the engines by pressing the bottom switches on the panels at the helm station.

Then use the top switches on the panel to start the motors.

Please read the engine instruction manual supplied with the boat carefully; it gives detailed explanations as to the best use of the engines and relative operations.

### ■ ENGINE START WITH BATTERY COUPLING

In case one of the start batteries is not available:

- Turn ON the coupling cut-out in the starboard engine compartment.
- Start the engine concerned.
- Turn the coupling cut-out to the OFF position.

Nota: in the standard configuration, the engine batteries are recharged by their respective engines.

## 2.4 Sailing

### ■ BEWARE

A catamaran is about 6 times more resistant to heeling than a monohull. In naval architecture, it is referred to as uprighting moment (multiplication of the weight of the boat by the transversal distance between the centre of gravity and the centre of floatation - or bottom).



This fact has real consequences as for the sailing and sail trimming of a catamaran. The fact that the boat does not heel may mask overcanvassing, which can be very dangerous for the crew and the boat. Therefore you must permanently keep a close eye on the speed of the true wind, and trim the sail surface according to the latter as a matter of priority.

The below-mentioned trims apply in a calm sea. When the sea is brown, you shall reduce earlier by 10% as far as the speed of true wind is concerned. And as a general rule, it is absolutely imperative to permanently try to ease up the boat rather than to stress her.

You will always try to have the forward edges of the sails facing the apparent wind, and to have the sail not sheeted home, so that the airflow behind the sail may be laminar, that is to say so that it may go off the aft part of the sail without any disruption.

In case you shouldn't follow the recommendations below, it might be dangerous for the boat and the crew, and, in case of an accident, the manufacturer's responsibility would not be involved.

### ■ TRIMMING WHEN CLOSE HAULED (between 75 and 50° of true wind)

Consult the owner manual  
Sailing configurations must be respected  
Sea state must be taken into account



Apparent Wind Angle   AWA : 30-70°				Apparent Wind Angle   AWA > 70°			
Apparent Wind Speed   AWS (Knots)	Main	Jib	Code 0	Apparent Wind Speed   AWS (Knots)	Main	Jib	Code 0
0-5	Full	0%	Full	0-16	Full	0%	Full
0-26	Full	Full	0%	0-20	Full	Full	0%
26-31	Reef 1	Full	0%	20-24	Reef 1	Full	0%
31-36	Reef 1	75%	0%	24-30	Reef 2	75%	0%
36-40	Reef 2	60%	0%	30-34	Reef 3   0%*	60%	0%
40-45	Reef 2	40%	0%	34-38	Reef 3   0%*	40%	0%
45-55	Reef 3   0%*	0%	0%	38-50	0%	25%	0%
> 55	0%	0%	0%	> 50	0%	0%	0%

\* 0% IF MAINSAIL WITH 2 REEFS

## 2.4 Sailing

### ■ TRIMMING WHEN DOWN WIND (between 75 and 130° of true wind)

- **From 0 to 20 knots:** full sail; the traveller can be set at different places ranging from 1 metre off the centre line of the boat to the end of the track, depending on the angle of the wind, the sheet is eased off so that the boom may be leeward and 50 cm far from the traveller in dead calm then up to 2 metres when the wind strengthens. In all the cases, you will avoid having more than one batten chafing against the upper shroud, in the fairest points of saling.

The jib is eased off in order to have its average front edge facing the apparent wind.

- **From 23 to 28 knots:** 1 reef, full jib. The trimmings are similar.

- **From 28 to 33 knots:** 2 reefs, 75% of the jib. The trimmings are similar.

- **From 33 to 39 knots:** 2 reefs, 50% of the jib. The trimmings are similar.

- **From 40 to 46 knots:** 3 reefs (or mainsail lowered and slightly more jib), jib 25%. The trimmings are similar.

- **From 47 to 55 knots:** 3 reefs only (or try sail, or lying to).

- **More than 55 knots:** scudding, depending on the sea, you will set mooring ropes from one transom extension to the other one in order to reduce the speed of the boat.

These figures are given for reference only and are to be adapted regarding external conditions.

### **CAUTION**

If there is a radar aerial on the mast, monitor the jib when tacking or jibbing to avoid any risk of damage.

### ■ BOOM

### **CAUTION**

For the standard boom, the crew must not climb on the boom without tightening the topping lift.

### ■ CRUISING SQUARE TOP MAINSAIL

### **CAUTION**

A cruising square top mainsail is more powerful than a standard mainsail. Shorten the sail earlier depending on the wind and sea conditions.

### MANOEUVRING PLAN - MAST BASE

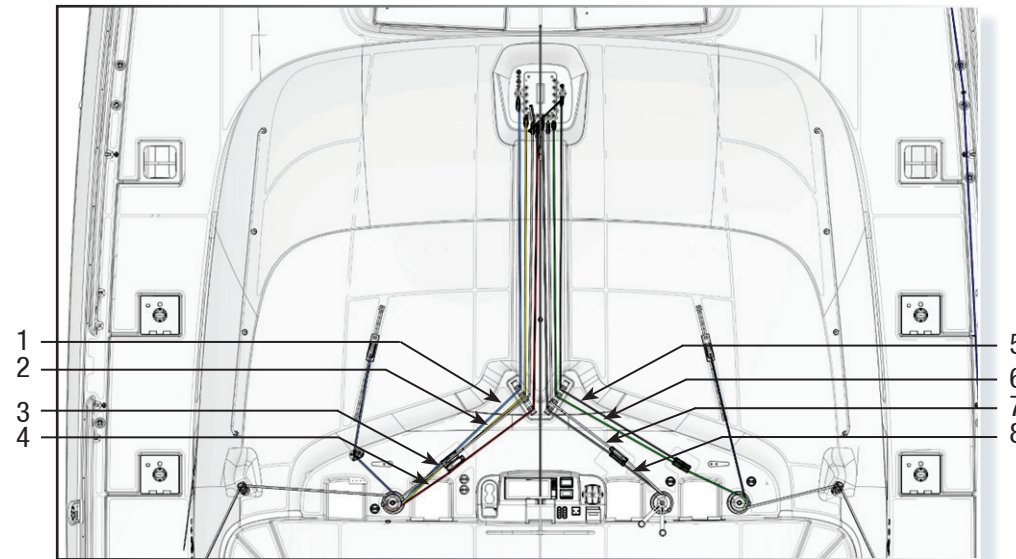

- 1 - Genoa halyard.
- 2 - Reef line 2.
- 3 - Spi and code 0 halyard.
- 4 - Reef line 3.

- 5 - Topping lift.
- 6 - Reef line 1.
- 7 - Mainsail halyard.
- 8 - Mainsail sheet.

#### ■ STANDARD MAINSAIL

To hoist the standard mainsail:

- Point the boat into wind with engine in gear.
- Make sure that the mainsheet is eased off and the reefs are free.
- Check that the halyard is not wound around the topping lift or itself.
- Open the jammer.
- Hoist taking care that the battens do not get stuck in lazy-jacks.
- Make fast the halyard with the jammer.
- Trim the mainsail according to the wind and sea conditions.
- Slacken off the topping lift.

To lower the standard mainsail:

- Haul up.
- Tighten the topping lift.
- Slacken off the halyard, lower the mainsail then furl it.
- Tighten the sheet.

#### CAUTION

During mainsail hoisting, ensure that the head pulley is blocked (Allen key) to avoid it turning on its own.

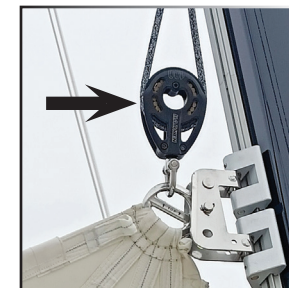

## 2.5 Sails

**MAINSAIL CRUISING  
SQUARE TOP SYSTEM**



**MAINSAIL CIRCUIT,  
GENOA AND CODE 0 FURLER**

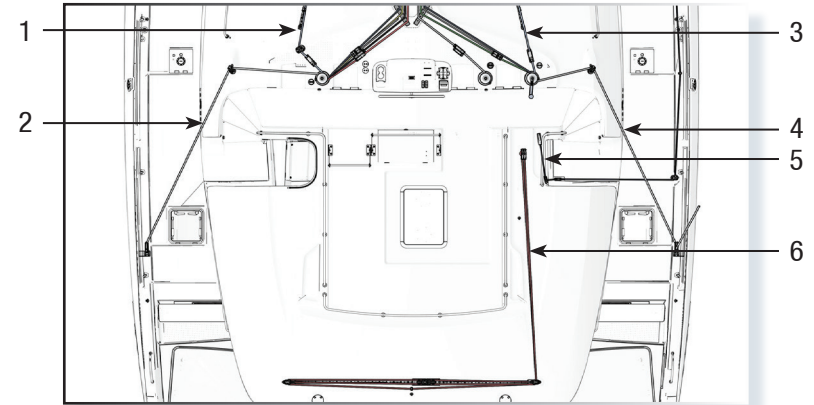

- |                            |  |
|----------------------------|--|
| 1 - Port genoa sheet.      | 4 - Starboard spi and code 0 sheet.                                  |
| 2 - Code 0 sheet (option). | 5 - Manual genoa furling line.                                       |
| 3 - Starboard genoa sheet. | 6 - Port and starboard mainsail car line.<br>+ line driver (option). |

### ■ CRUISING SQUARE TOP MAINSAIL (option)

The cruising square top mainsail halyard is lashed on the eyelet of the sail, not on the headboard traveller.

The square top will be properly set automatically once the sail is hoisted up.

### FITTING OF THE MAINSAIL CRUISING SQUARE TOP SYSTEM

- Remove the pin of the headboard car.
- Make the 2 strand tackle
- Put back the headboard car pin, adding the sheave.

The length of the headboard line is adjusted to the right dimension for a new sail at the sailmaker's.

Lashing makes it possible to compensate for the possible lengthening of the rope due to ageing.

### **CAUTION**

A cruising square top mainsail is more powerful than a standard mainsail.

Shorten the sail earlier depending on the wind and sea conditions.

### GENOA FURLER

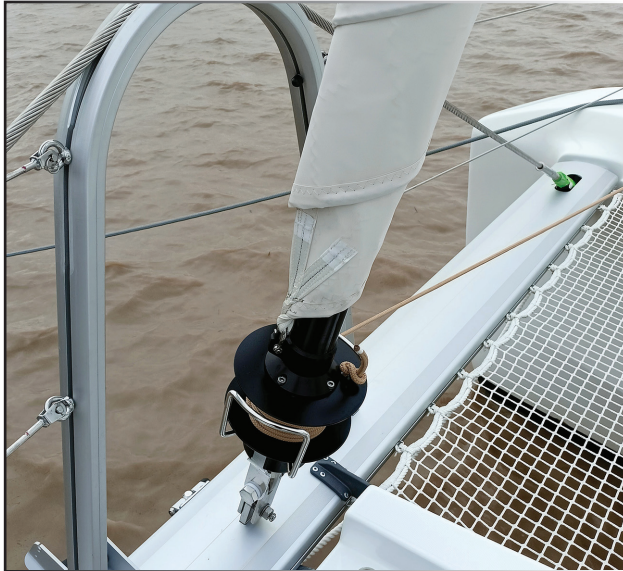

### MARKING OF THE GENOA'S FURLING DIRECTION



#### ■ REEFING A SAIL

Automatic reefing system:

- Move upwind.
- Release the tension on the downhaul.
- Ease off the mainsail sheet slightly.
- Ease off the mainsail halyard.
- Take hold of the reef line.
- Pull on the mainsail halyard to tighten it.
- Adjust the mainsail sheet.
- Pull on the downhaul to tighten if necessary.

During automatic reefing, the mainsail halyard must not be released too far (risk of incorrect placement of the pulleys).

#### ■ ROLLER FURLING GENOA

Set up the genoa before sailing, at a moment when there is no wind.

- Fasten the halyard point.
- Fasten the halyard on the swivel slider.
- Fasten the tack fitting on the drum and the sheets.
- Hoist the genoa by engaging the headline in the sail feeder taking care to avoid tearing.
- Tighten the halyard sufficiently but not as tense as a sail on a forestay.
- Hoist to remove the horizontal folds (adjust the luff tension after a few trips at sea).
- Secure the clew.
- Pull the line from the cockpit to furl the genoa.

## 2.5 Sails

### USING THE GENOA

- Gradually ease off the genoa roller furling stopper by pulling a sheet.
- Pull on the line to furl the genoa.

#### **CAUTION**

Take care with the drum's winding direction: the genoa's anti-UV protection must be on the outside.  
Never force in case of hard point during the winding or unwinding of the fore sails.  
Check that there is no halyard caught in the furler or that the sail is not too tightened.

### ■ ELECTRIC BOW SPRIT AND GENOA FURLERS (OPTION)

The circuit breakers for the genoa and bow sprit furlers are located in the starboard locker on the foredeck.

The furler controls are located on the helm station to port.

#### **ELECTRIC FURLER CIRCUIT BREAKERS**

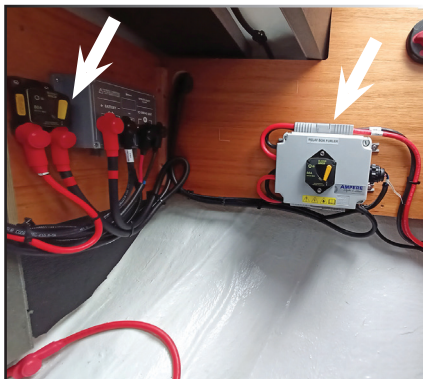

#### **ELECTRIC FURLER CONTROLS**



### ■ CODE 0

It is possible to remove the front guard lines when using the code 0.

Before getting under the way, take advantage of a windless period of time and hoist the code 0.

- Secure the swivel to the code 0 headboard.
- Secure the furling system to the tack clew.
- Put the furling system to the boomsprit with a snap shackle.
- Secure the halyard to the headboard swivel.
- Hoist the code 0.

Use the furling system line to furl or unfurl the code 0.

Code 0 sheets:

- Secure the sheets to the code 0 clew.
  - The sheets pass to the exterior of the forestay and the shrouds.
- Upwind, pass the sheets to the interior of the guard lines and downwind to the exterior of the guard lines.
- Make fast the sheet leading blocks to the chainplates with a loop (textile loop).
  - Reroute the sheets to the external winches.

#### **CAUTION**

Under certain configurations, the code 0 can hide the fore navigation lights.

#### **CAUTION**

Unrig the code 0 when not in use (risk of being UV damaged and inadvertently unfurled).

### ELECTRIC WINCHES CIRCUIT BREAKERS



- SHEET WINCHES AND MANOEUVRE WINCHES (MANUAL OR ELECTRIC) (OPTION)  
Electric winch circuit breakers are located behind a hatch in the cabinet at the saloon starboard entrance.

#### RECOMMENDATION

Make at least 3 turns of the winch.  
Electric winches generate an extremely powerful force and must be used with precaution.  
Never force when you find a jamming point.  
When using the winches, keep your hands away.

#### CAUTION

Refer to the manufacturer's instructions to remove the winches and put them back.  
Improper refitting may result in accidents (for example: kick of the crank handle).

- Running rigging

Description of the ropes	Length (m)	Diameter (mm)
Mainsail halyard	48 + 23	12 + 10
Mainsail topping lift	52	12
Option Reef 1 auto	30	14
Option Reef 2 auto	45	14
Reef 3	40	14
Mainsail sheet	40	14
Port traveller adjustment	17	10
Starboard traveller adjustment	14	10
Genoa halyard	27 + 20	12 + 10
Port genoa sheet	13.5	12
Starboard genoa sheet	13.5	12
Genoa furling line	29	10
Adjustment of the mainsail car toothed pulley + lashings for the adjustment of the mainsail car	16.7	10
Gennaker halyard	40 + 35	12 + 10
Port gennaker/spi sheet	37	12
Starboard gennaker/spi sheet	37	12

## 2.6 Electronics

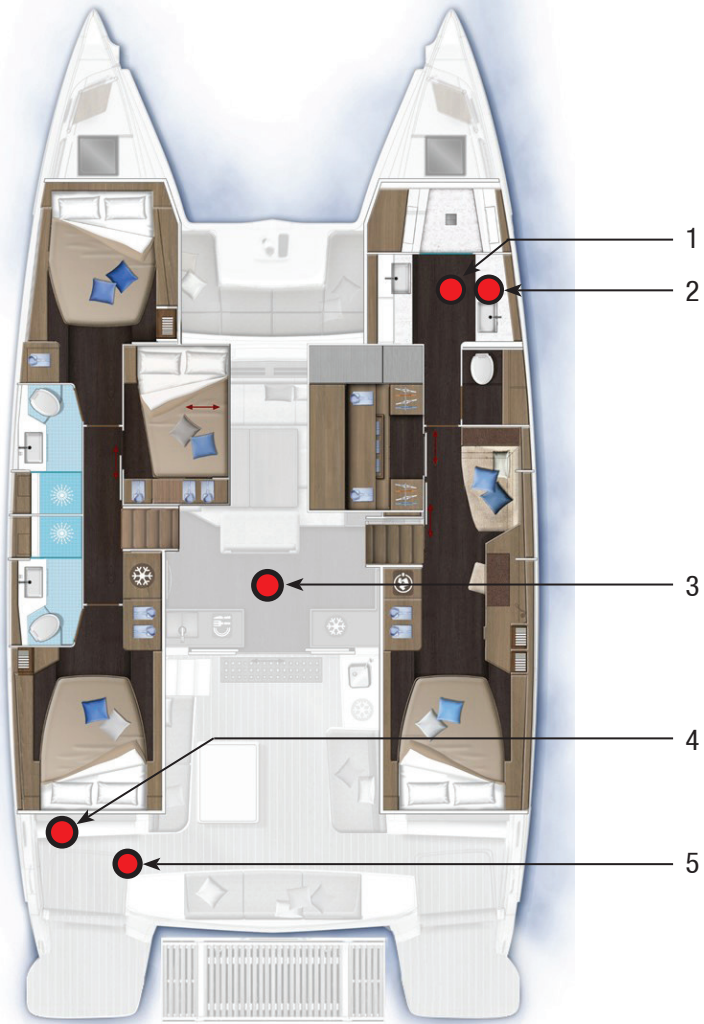

*Note: the locations are the same in the other equipment versions.*

**PILOT COMPASS**

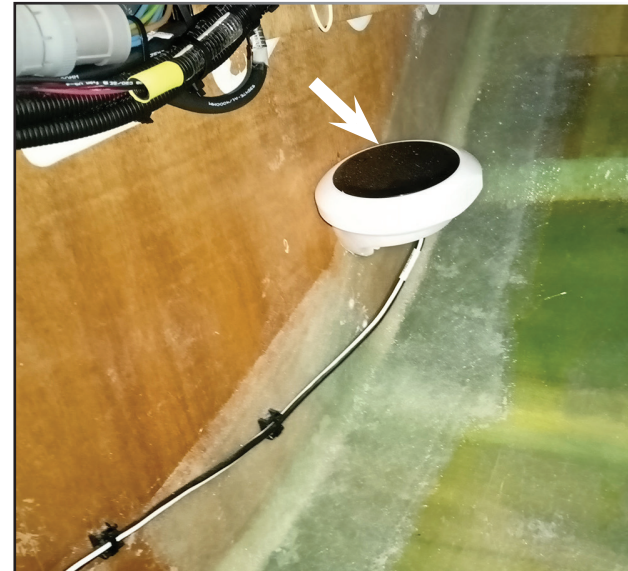

- 1 - Log + depth sounder sensors.
- 2 - Compass of the automatic pilot.
- 3 - Electronic boxes.
- 4 - Hydraulic cylinder.
- 5 - Calculator.

## 2.6 Electronics

TRI-FUNCTION SENSORS AND REALVISION



PILOT CALCULATOR

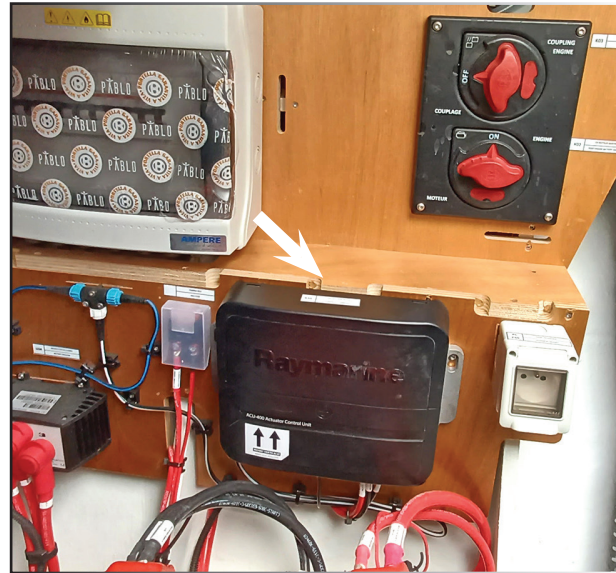

HELM CYLINDER FOR AUTOPILOT

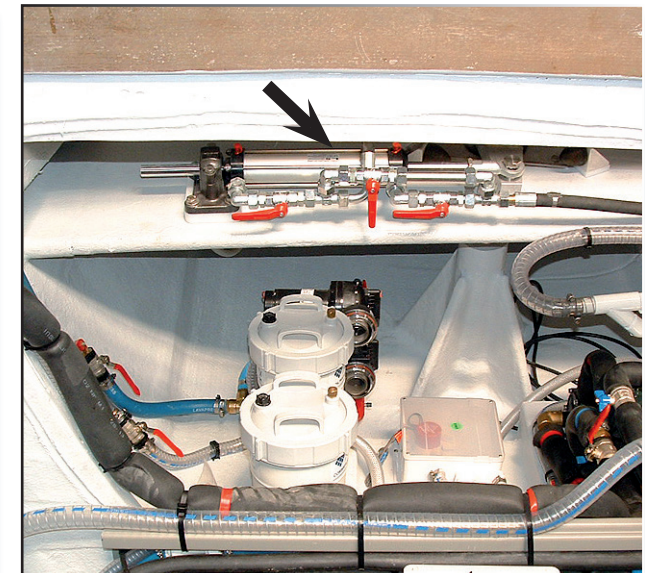

### ■ ELECTRONICS

The boat may be fitted with an optional electronic pack and different navigation aid accessories.

The ram and the alculator are in the port side engine compartment.

The automatic pilot fuse is in the calculator.

The electronic boxes are located in the ceiling.

The compass and Loch Speedometer probe are located under the forward starboard floor.

For the use and maintenance of all these components, please refer to their instruction guides.

### **CAUTION**

Make sure you do not put close to the compass any objects that could disturb its magnetic field (metal or electric objects).



# ANCHORING - MOORING

---

# 3

**3.1 Bow thruster**

**3.2 Anchoring**

**3.3 Davits**

**3.4 Tenderlift**

### 3.1 Bow thruster

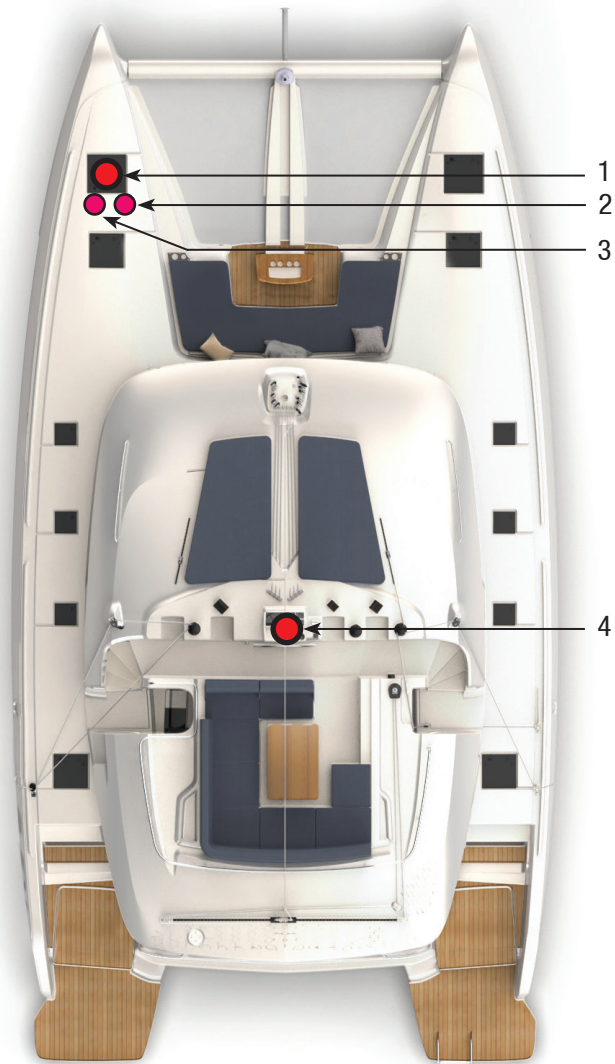

- 1 - Bow thruster.
- 2 - System box.
- 3 - Bow thruster fuse.
- 4 - Thruster control.

#### BATTERIES + FUSE + BOW THRUSTER

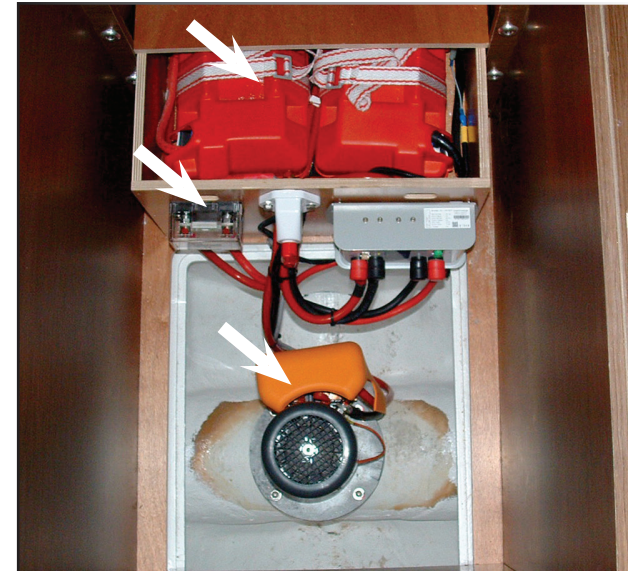

#### ■ BOW THRUSTER

The boat may optionally be equipped with a bow thruster.

The bow thruster functions with 24 V off an independent battery bank (4 x 50 Ah / 12 V).

The bow thruster and its batteries, cut-out and fuse as well as its charger are located in the port side bow.

The 12 / 24 V charger charges the battery bank at 24 V using the 12 V on board battery bank.

The charger works automatically once the on board circuit is switched on.

Monitor the Thruster battery bank voltage using the multifunction touch screen.

## 3.1 Bow thruster

THRUSTER CONTROL



DETAILS OF THRUSTER CONTROL



BATTERY CHARGER FOR THE THRUSTER



The bow thruster is controlled from the helm station.

Having switched on the on board and thruster cut-out and started the engines:

- Press for three seconds on the yellow thruster control switch. The yellow LED - which flashes when the thruster is switched on - remains lit. The control can then be operated.

- Manoeuvre by using the required button (port or starboard) on the control.

Disconnect the control by pressing on the yellow switch a second time. The LED will start flashing again.

Note: after 3 minutes without operation, the thruster goes OFF.

In case of a malfunction, check the fuse located in the fore peak on the port side. Please refer to the user manual for information about the use and maintenance of the bow thruster.

**DANGER**

Never extract the fuse while the bow thruster is operating.

## 3.2 Anchoring

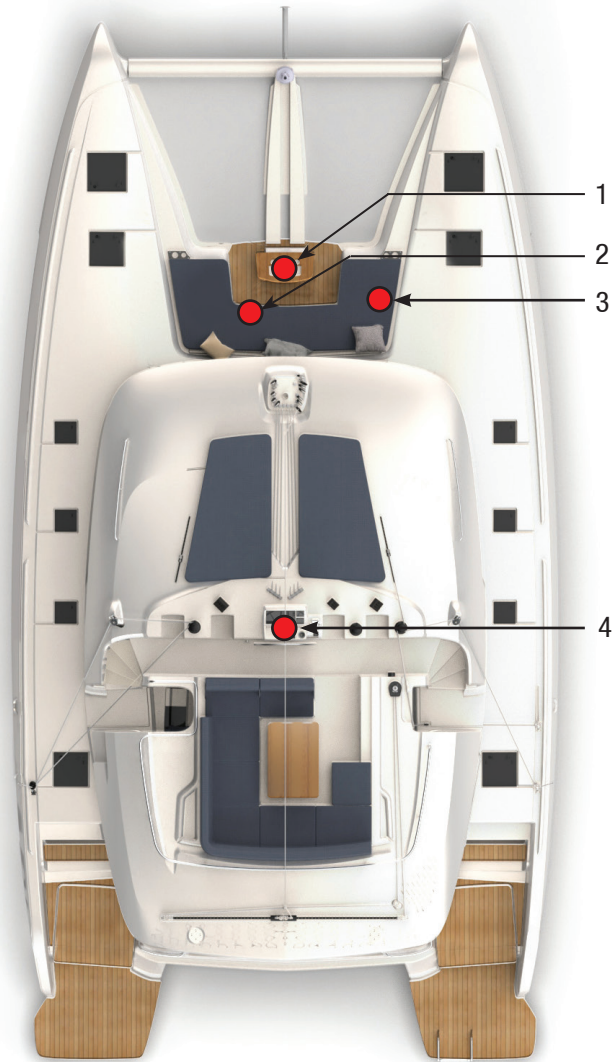

- 1 - Electric windlass.
- 2 - Electric windlass remote control.
- 3 - Windlass automatic breaker.
- 4 - Chain counter.

### CHAIN COUNTER



#### ■ WINDLASS

The electric windlass is powered by the 12 V on board batteries.

Operate the windlass from the helm station (chain counter option) or by its control in the port foredeck locker.

#### **RECOMMENDATION**

The electric windlass should be used with one or two engines running.

If the electrical windlass does not function properly, check its automatic breaker located in the starboard foredeck locker.

Refer to the manufacturer's manual for use and maintenance of the windlass.

## 3.2 Anchoring

**ELECTRIC WINDLASS  
CIRCUIT BREAKER**

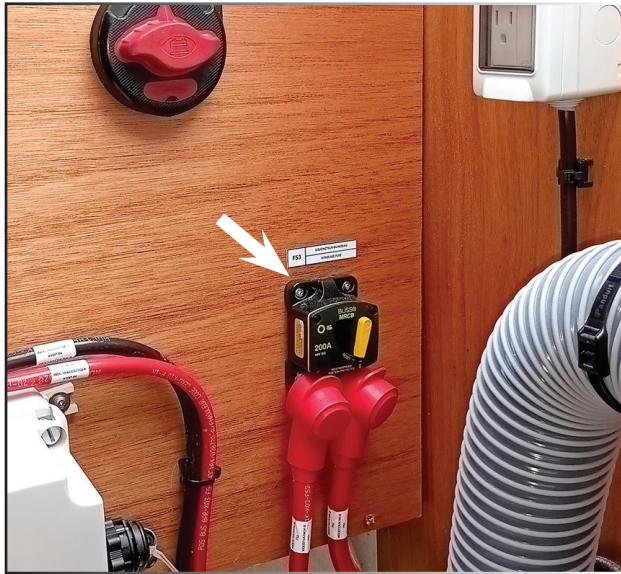

**ELECTRIC WINDLASS  
REMOTE CONTROL**

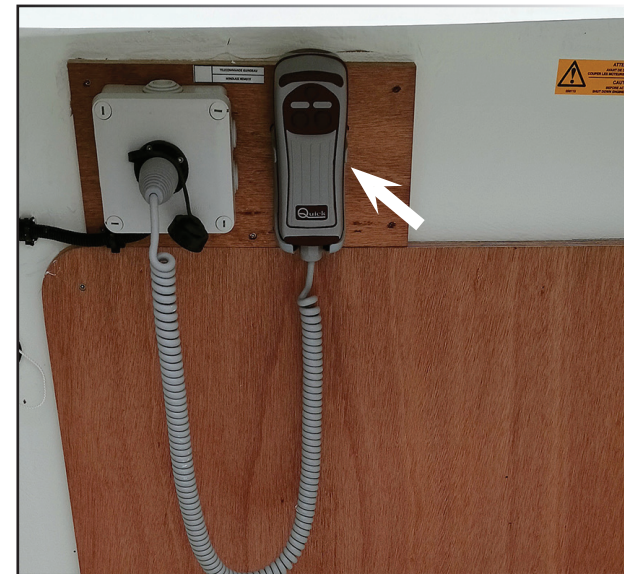

### ■ PREPARING ANCHORING

Set the strop fastening it to the chainplates at the ends of the main beam.  
Insert the strop inside the stem anchor roller.  
Make fast the strop to the central cleat when lowering the chain.

Note: the boat can be equipped with an optional chain counter.

#### **RECOMMENDATION**

Before you anchor, check the type of the sea bed, the depth of water and the strength of the stream.

The standard calibration zero corresponds to the anchor position ready to be dropped.  
Please read its use and maintenance instructions.

### ■ ANCHORING

Have your boat head wind and without speed.  
Pay out the chain while moving back slowly.  
Secure the chain on the strop.  
Release the chain until the strop is taut.  
Pay attention to the swinging space when mooring.

#### **RECOMMENDATION**

Secure the chain with a shackle or some on the cleat if it is not completely unwound. You shall not use the windlass grab to fasten the ground tackle.

## 3.2 Anchoring

### STROP CIRCUIT



#### ■ LIFTING THE ANCHOR

- Ensure that the chain is properly set on the gypsy.
- Activate the windlass in the upward position.
- Slowly go near the anchor using the engine (do not use the windlass force to winch up the boat).

Unfasten the pendant.

When raising the anchor, check regularly that the chain doesn't block in the windlass hatch.

Visually check the final metres until the anchor makes contact with the anchor roller.

Check the position of the anchor on the stemhead fitting.

Rinse the windlass and the ground tackle with fresh water after each trip.

Use the winch handle to loosen the windlass during anchorage.

#### **CAUTION**

Windlass operations are dangerous:

- Always keep the ground tackle clear and free. Always proceed with care, wearing gloves and always wearing shoes.
- Make sure that nobody leans on the windlass when operating the control.

#### **RECOMMENDATION**

Insert a marker on the last metres of the chain (paint, elastic rubber etc.) to facilitate the manoeuvre and to anticipate a sudden arrival of the anchor.

### DAVIT



#### ■ DAVIT

The boat is equipped with a davit system with a dedicated manual winch. It can be optionally equipped with an electric winch system.

#### **CAUTION**

Nobody should be on board or under the tender during manoeuvres carried out with the davits.  
Tie up the tender during manoeuvres.

#### **CAUTION**

The davit is designed to withstand a maximum load of 250 kg and a maximum length tender of 3.40 metres.

#### ● INSTALLING A TENDER ONTO THE DAVITS

After removing the tender equipment:

- Lower the davit system as close as possible to the tender.
- Fix the tackle hooks located on the davits to the fore and aft of the tender.
- Close the blocker located on the port side of the davit system.
- Raise the davit and tender using the manual manoeuvring winch or the electric winch (option).
- Once in the top position, secure the davit system and tender using the hook.
- Remove the water drain plug from the tender.

#### ● LAUNCHING A TENDER FROM THE DAVIT

Replace the water drain plug on the tender.

- Open the lines for the port and starboard gunwhales
  - Ensure that the blocker on the davit is closed.
  - Pass the davit line around the winch (make at least three turns).
- After having removed the hold safety devices and moored the tender:
- Open the blocker and let the line run gently until the tender reaches the water.
  - Cast off the tackle hooks on the davit to the fore and aft of the tender.
  - Remount and secure the davit system.

While sailing, remove the tender engine and store it on the boat.

Secure the tender according to the sailing conditions and sea conditions.

Install safety equipment on board the tender in accordance with the regulations of the registration country of the boat.

## 3.4 Tenderlift

TENDERLIFT



TENDERLIFT REMOTE CONTROL



TENDERLIFT HYDRAULIC PUMP



### ■ TENDERLIFT

The boat may optionally be fitted with a hydraulic Tenderlift. It is automatically switched on when the on board general battery cut-out switch is ON.

The control is located in the port engine compartment. A radio remote control is also supplied with the boat. Turn off the remote control after use.

### CAUTION

The tenderlift is designed to withstand a maximum load of 250 kg and a tender of a maximum length of 3.40 metres.

In case of malfunctioning, check the fuse in the port engine compartment.

The Tenderlift has two panels that when folded act as cradles for the tender and once deployed expand the reception area.

When sailing, stow the tender on the cradles and secure the folded panels with straps.

Attach the tender laterally to the inter-transom cleats

## 3.4 Tenderlift

**TENDERLIFT  
FOLDING PANELS**



**TENDERLIFT  
PANELS UNFOLDED**



***DANGER***

It is strictly prohibited to sail when the tenderlift is in a position other than the utmost raised one.  
When sailing, the tenderlift must be locked in the high position with the turnbuckles.



# LIFE ON BOARD - EXTERIOR FEATURES

---

4

- 4.1 Stern cockpit**
- 4.2 Fore cockpit**
- 4.3 Flying bridge**
- 4.4 Swim area**

## 4.1 Stern cockpit

**COCKPIT TABLE**



■ **COCKPIT TABLE**

As standard, the boat is equipped with a composite fixed table.  
As an option, the boat can be equipped with a large folding teak table, port side.  
Unfold the extensions under the table before opening the panels.

**COCKPIT SINK**



■ **COCKPIT SINK**

The cockpit cabinet is equipped with a sink and cold / hot water mixer tap.  
The mixer tap works once the 12 V on-board circuit and water unit switch are switched on at the electric panel in the starboard companionway.

The cabinet can optionally include a 220 V icemaker or an 80 litre 12 V refrigerator.  
For more details, see chapter LIFE ON BOARD - GALLEY.

**PUSH / PULL LAMP**



■ **PUSH / PULL LIGHTING**

The cockpit is fitted with retractable lights located in the flat surrounds.  
Lower the lights into their housing before setting sail.

## 4.2 Fore cockpit

FORE COCKPIT BENCH



### ■ FORE COCKPIT BENCH

Fasten the sundeck cushions before sailing.

#### **CAUTION**

When sailing on rough seas, do not stay in the fore cockpit area for safety reasons.

DECK WASHING PUMP CONNECTION



### ■ DECKWASH PUMP

The boat may be optionally equipped with a deck wash pump.

The deck wash pump is located in the port side locker of the fore cockpit. It provides seawater or fresh water from the tanks.

The freshwater or seawater selection valve is located next to the pump, in the port locker of the fore cockpit.

Switch on the deck wash pump using the switch located above the pump.

Open the sea water inlet valve located in the port sump before use.



DECKWASH PUMP

## 4.3 Flying bridge

### FLYING BRIDGE SUN DECKS



#### ■ FLYING BRIDGE SUN DECKS

Fasten the sundeck cushions before sailing.



4. LIFE ON BOARD - EXTERIOR FEATURES

## 4.4 Swim area

### SWIM LADDER

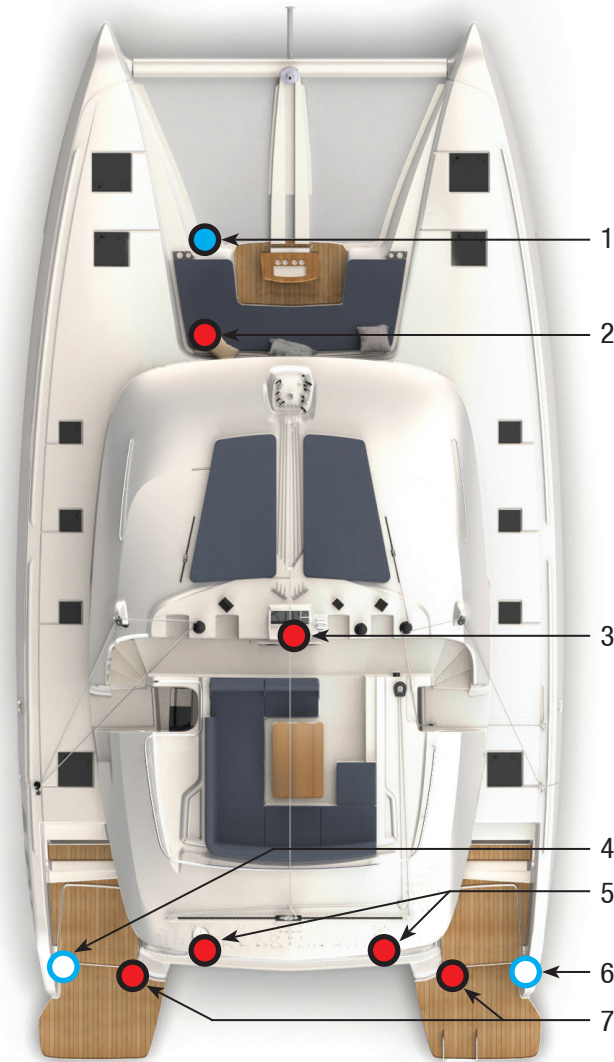

- 1 - Hose connection to the deck wash pump.
- 2 - Deck wash pump + 3-way valve for freshwater/sea water + power switch.
- 3 - Control for underwater + rear spotlights.
- 4 - Optional cockpit shower.
- 5 - Aft beam spotlights.
- 6 - Cockpit shower.
- 7 - Underwater spotlights.



#### ■ SWIM LADDER

The rear starboard transom incorporates a folding swim ladder. A second swim ladder is available as an option on the port side (with the optional second cockpit shower).

Always raise the swimming ladder before sailing.

## 4.4 Swim area

### SHOWER



#### ■ SHOWER

The cockpit shower with hot / cold tap is located in the side of the starboard aft transom.

A second cockpit shower is available as an option. It is installed on the side of the port aft transom.

Before use, turn on the 12 V on-board circuit and the water unit via the switch on the electrical panel in the starboard hull companionway.

#### ■ AFT BEAM SPOTLIGHTS

The boat may be fitted with optional aft beam spotlights.

After switching on the 12 V on-board circuit, operate the spotlights with the switch at the helm.

### AFT BEAM SPOTLIGHT + SPOTLIGHT CONTROL



#### ■ UNDERWATER SPOTLIGHTS

The boat may be fitted with four optional underwater spotlights.

After switching on the 12 V on-board circuit, operate the underwater spotlights with the switch at the helm.

#### **CAUTION**

After use, check that the spotlights and their switches are OFF.

### UNDERWATER SPOTLIGHT + SPOTLIGHT CONTROL





# LIFE ON BOARD - LIVING SPACES

---

# 5

**5.1 Saloon**

**5.2 Televisions - HiFi**

**5.3 Windows**

**5.4 Washer-dryer**

**5.5 Air conditioning**

## 5.1 Saloon

**FOLDABLE SALOON TABLE  
+ RAISE/LOWER SWITCH**



**FOLDABLE SALOON TABLE**



**GALLEY STORAGE**



### ■ SALOON TABLE

The saloon is equipped as standard with a wooden table with fixed leg. Optionally, the saloon can be equipped with a larger, foldable, wooden table with electric raise/lower system. The table's raise/lower switch is located under the chart table.

### ■ FLOORBOARDS

The floorboards can be lifted up to have access to the different technical components on board.

### **RECOMMENDATION**

To avoid premature ageing of the floorboards (dents, scratches), it is recommended to keep them as clean as possible, and to take one's shoes off before entering.

### ■ STORAGE

The galley has plenty of storage space to hold food, cutlery, bottles, etc.

### ■ DRAWERS

The drawers in the galley have an automatic closing function. Gently push the drawer until the movement completes automatically.

To remove a drawer: open fully and unclip by lifting it up. When reassembling, clip the drawer before pushing it back in.

### MULTIFUNCTION TOUCH SCREEN



### SALOON TELEVISION



#### ■ ON-BOARD LIGHTING

After switching on the 12 V circuit and the control touch screen:

- Use the touch screen to select the Lighting Menu icon.
- Move to the Lighting zone sub menus and select the areas of the boat to be lit.

Turn on the lights using the switches in the desired zone.

Please refer to chapter 1.3 Control touch screen for details.

#### ■ TELEVISION

The saloon can be optionally fitted with a television located under the hatch next to the chart table.

After switching on the 12 V on-board circuit:

- Check that the circuit breaker is on at the Comfort busbar in the cupboard behind the switchboard in the starboard hull companionway.
  - Open the television hatch.
- Return the TV to its original position for navigation.

The owner's cabin can be optionally prewired to take the television (three cabin version).

For the use and maintenance of the televisions, please refer to their instruction manuals.

## 5.3 Windows

**CABIN PORTHOLE**



**SUNROOF GLAZING**



**BLIND + MOSQUITO NET FOR DECK HATCH**



### ■ PORTHOLES AND DECK HATCHES

The portholes and deck hatches are fitted with locking systems to keep them in a closed position.

At anchor, intermediate opening positions allow for airing the boat.

The deck hatches are fitted with a blind and mosquito net system, which can be used even when a hatch is open.

You shall handle them with care.

The saloon can optionally be equipped with a large sliding sunroof window.

### **CAUTION**

When sailing, always close the large roof glazing.

### ■ WINDOW BLINDS

The cabins are equipped as standard with blackout blinds.

The saloon is equipped with a roof blackout curtain.

Optionally, cabin windows are equipped with blackout roller blinds.

The bay window and the saloon can also optionally be equipped with a blackout roller blind.

## 5.4 Washer-dryer

### WASHER DRYER



### FRESH WATER SUPPLY VALVES



- 1 - Fresh water supply valve for the washing machine.
- 2 - Washer-dryer.
- 3 - Washing machine discharge valve.

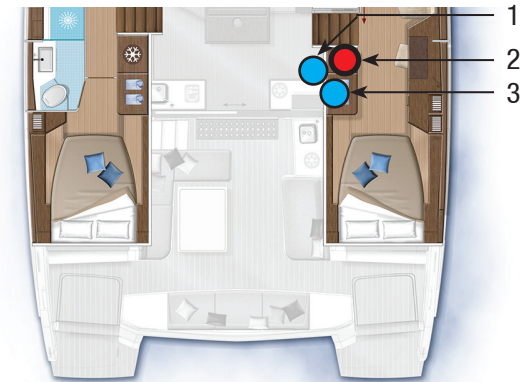

Note: the locations are the same in the other equipment versions.

#### ■ WASHER-DRYER

The boat can optionally be equipped with a washer-dryer located in the low cabinet of the starboard gangway.

The washing machine is supplied with fresh water from the starboard tanks.

Check that the valve located under the floor in front of the washing machine is open and ensure that the water unit switch on the electrical panel is on and that the fresh water tanks are full.

In the US version, check that the water heater is operating, and open the two water supply valves (cold water and hot water).

Draining is via the valve located under the floor in front of the washing machine.

- Check that its automatic breaker is switched on at the Power busbar in the cupboard behind the switchboard in the starboard hull companionway is on.

#### SUPPLY

Select the power source (generator or shore power supply number 1) from the left selector in the starboard hull companionway.

#### RECOMMENDATION

The washer-dryer should not be used while sailing.

#### CAUTION

The Washing, spinning, drying program of the washing machine exceeds the capacity of the grey water tank: it should therefore only be used in direct drainage (see p.71).

For the use and maintenance of the washer-dryer machine, please refer to its instruction guide.

## 5.5 Air conditioning

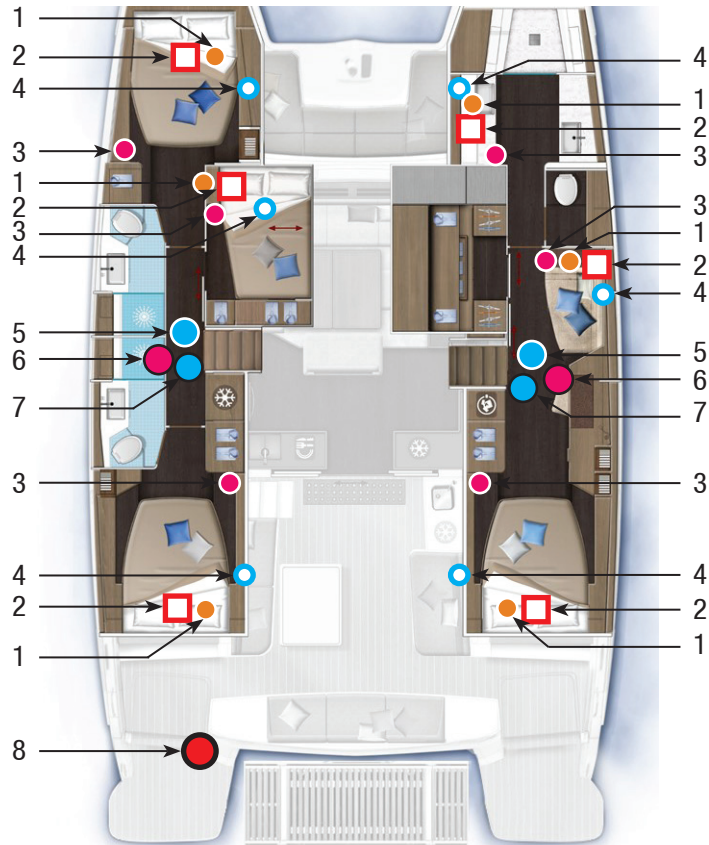

Note: layouts vary according to the version.

- 1 - Drain pump.
- 2 - Forced air heater.
- 3 - Air conditioning control.
- 4 - Drainage valve of the air conditioning.
- 5 - Sea water filter.
- 6 - Electric pump.
- 7 - Sea water inlet valve.
- 8 - Circuit breaker for components - air conditioning.

### AIR CONDITIONING CONTROLS



#### ■ AIR CONDITIONING

The boat may be fitted with an optional reversible air conditioning system.

The air conditioning units (air heaters) are located in the cabins and in the saloon. Ventilation vents are installed in each cabin, shower room and in the saloon. The air conditioning units operate independently.

## 5.5 Air conditioning

**PUMP + SEA WATER FILTER**

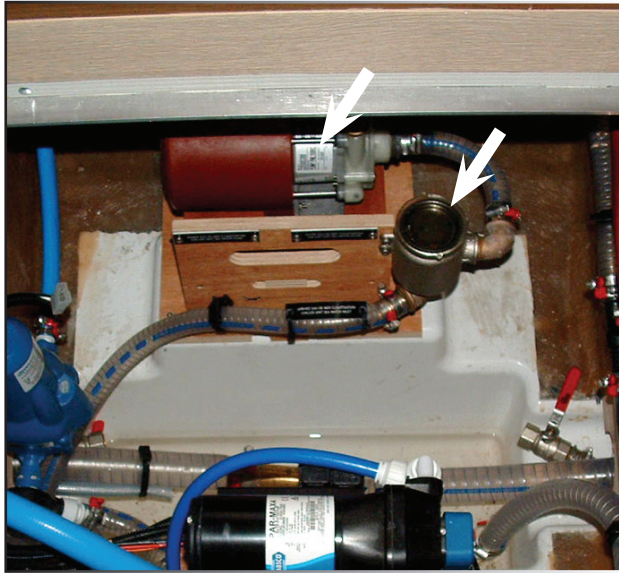

**SEAWATER INLET VALVE**

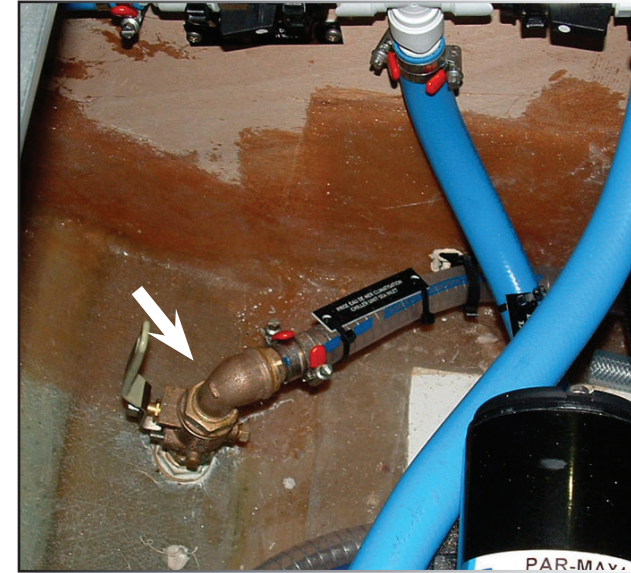

Before starting the system:

- Open the seawater circuits (intake valves under the port and starboard gangways at the foot of the companionways).

### SUPPLY

Select the power source (generator or shore power supply No. 2) from the right selector in the starboard hull companionway.

Check that the pumps and air conditioning units are switched on at the automatic breakers located in the port engine compartment.

Switch on the air conditioning unit in the required zone then select hot or cold and set the temperature from the control.

Regularly clean the filters on the air conditioning circuits and on the seawater intake valves.

For purging, use and maintenance of the air conditioning system, please refer to its instruction manual.



# LIFE ON BOARD - GALLEY

---

# 6

**6.1 Fresh water**

**6.2 Watermaker**

**6.3 Icemaker**

**6.4 Dishwasher**

**6.5 Refrigerators - freezer**

**6.6 Gas oven and hobs**

**6.7 Microwave oven**

**6.8 Cockpit plancha**

## 6.1 Fresh water

### SHORE FRESH WATER FILLERS



### Supply valves / WATER UNIT UNDER PRESSURE

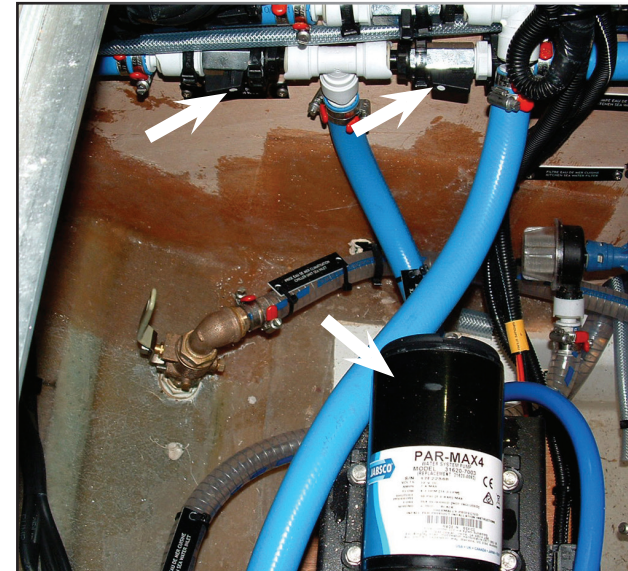

#### ■ FRESH WATER TANKS

The boat is equipped as standard with two 240-litre freshwater tanks and two 175-litre tanks.

Each hull has two reservoirs connected together however, the port and starboard hulls are independent.

The tanks are connected and are filled by one deck fitting for each hull.

Use the supply valves in the port sump to select either the port or starboard tank for the water unit supply.

To prevent any handling mistake, never fill the water and fuel tanks at the same time.

During filling, avoid handling contaminants near the fillers.  
Open and close the filler caps with the correct key.

Check the filler cap seals for condition during filling.

The tanks are fitted with overflow outlets and vents.

Never insert the water filling hose deep down into the system in order to prevent any over-pressure in the systems.

Note: the capacity of the fresh water tank(s) indicated on the SPECIFICATIONS page may be not completely usable depending on the trim and load of the boat.

## 6.1 Fresh water

### WATER UNIT START SWITCH



#### RECOMMENDATION

Pay attention to the quality of the water for the filling up. Check if the water is drinking water. If the boat is not used for long, purify the tanks and pipes with proper treatment.

#### ■ WATER UNIT

The water unit is located under the floor at the port sump. Start this using the switch on the electrical panel.

If it does not work, check its fuse in the protection module behind the electrical panel.

#### RECOMMENDATION

Never operate the water system equipment when the valves are closed or when the tanks are empty (the electrical equipment may be damaged). Check the different water filters for condition.

- 1 - Fresh water tank (175 l).
- 2 - Deck filler.
- 3 - Touch screen (tank gauges).
- 4 - Power switch for the water unit.
- 5 - Water unit.
- 6 - Fresh water tank (240 l).
- 7 - Watermaker.
- 8 - Water heater.
- 9 - Shore fresh water supply.

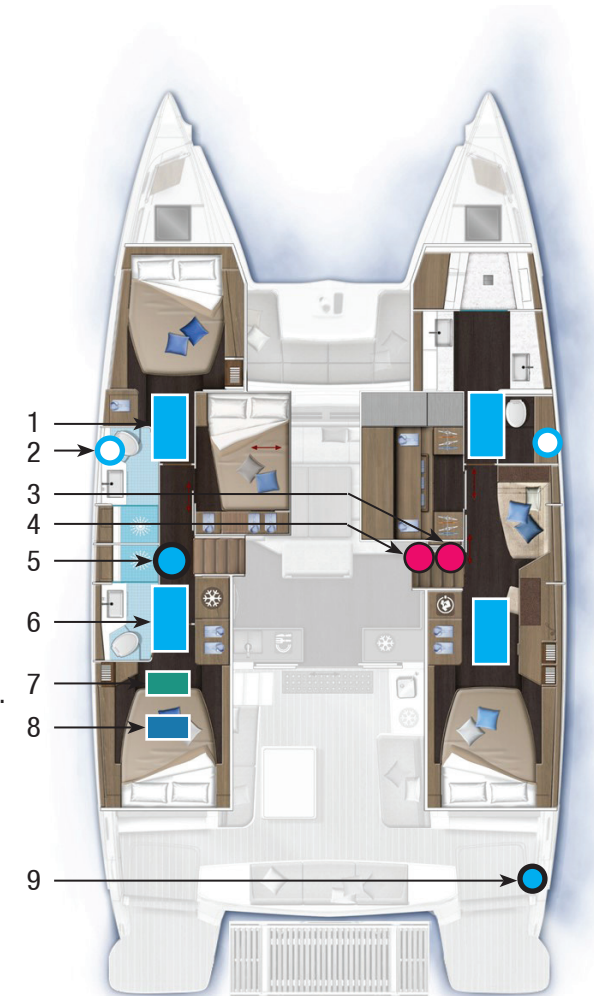

*Note: the locations are the same in the other equipment versions.*

## 6.1 Fresh water

**CONTROL TOUCH SCREEN  
DIRECT ACCESS TO TANK GAUGES**



**CONTROL TOUCH SCREEN  
CHOICE OF GAUGE TO READ**

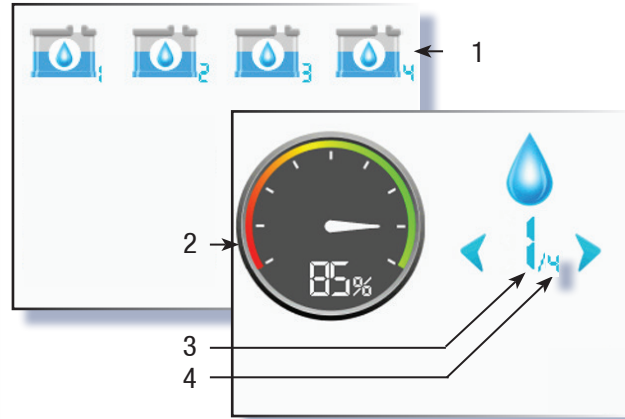

- 1 - Access to tanks gauges.
- 2 - Tank level.
- 3 - Tank number.
- 4 - Number of tanks on board.

**SHORE FRESH WATER SUPPLY**



### ■ WATER GAUGES

Check the water level in the tanks using the touch control screen in the cupboard on the side of the chart table.

### **RECOMMENDATION**

When the reservoir is empty, turn off the corresponding water unit to avoid damage to the unit.

### ■ SHORE FRESH WATER SUPPLY

The boat is equipped with a shore freshwater supply connection, at the starboard entrance of the cockpit.

To use the marina fresh water:

- Connect the shore supply.
- Turn the water unit switch to OFF.

## 6.1 Fresh water

**WATER HEATER**

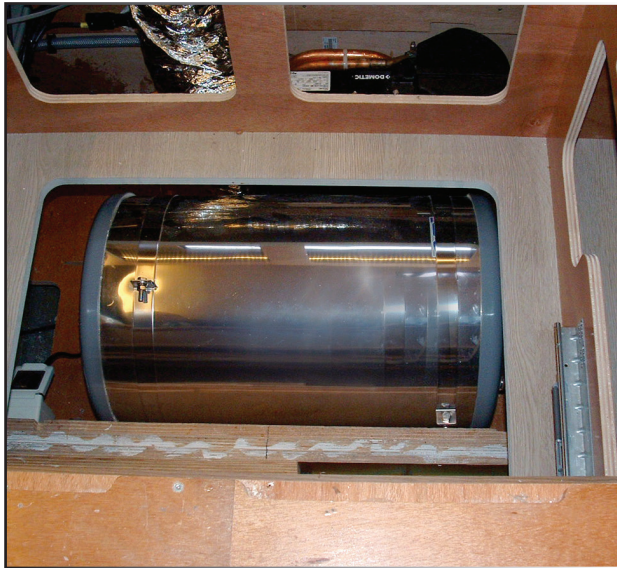

**THERMOSTATIC VALVE**

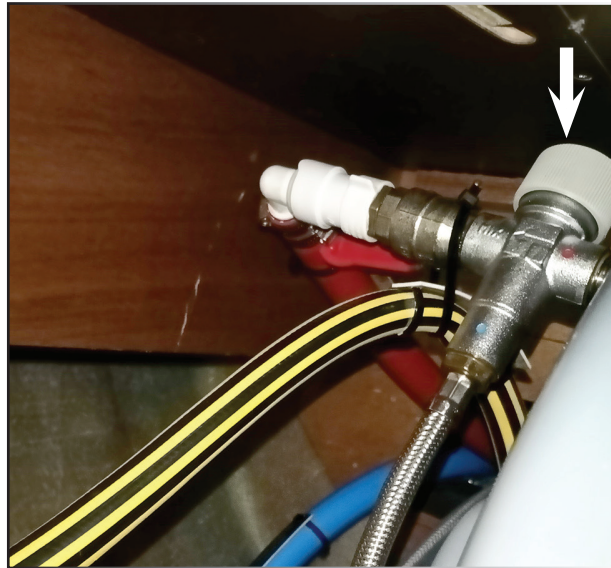

**WATER HEATER CIRCUIT BREAKER**

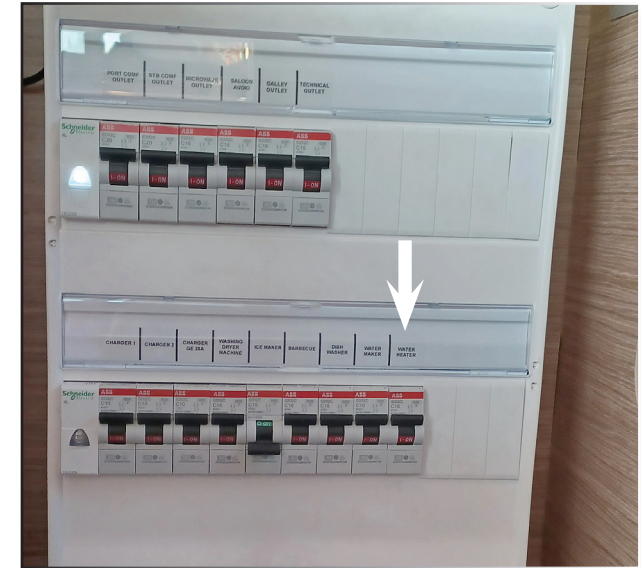

### ■ WATER HEATER

The water heater has a volume of 60 litres.

The water heater is located under the bed of the aft port cabin.

The water heater will operate automatically when the port engine is running, or on 220 V upon connection to the shore power or when the generator is running.

- Check that its automatic breaker is switched on at the Power busbar in the cupboard behind the switchboard in the starboard hull companionway is on.

The hot water temperature is pre-set using the thermostatic valve located on the water heater.

### **RECOMMENDATION**

When the water heater is not used, switch off its 220 V circuit. Before starting it by switching on the 220 V circuit, ensure the water heater is full of water.

## 6.2 Watermaker

**WATERMAKER CONTROLS**



**WATERMAKER  
+ FILTERS**

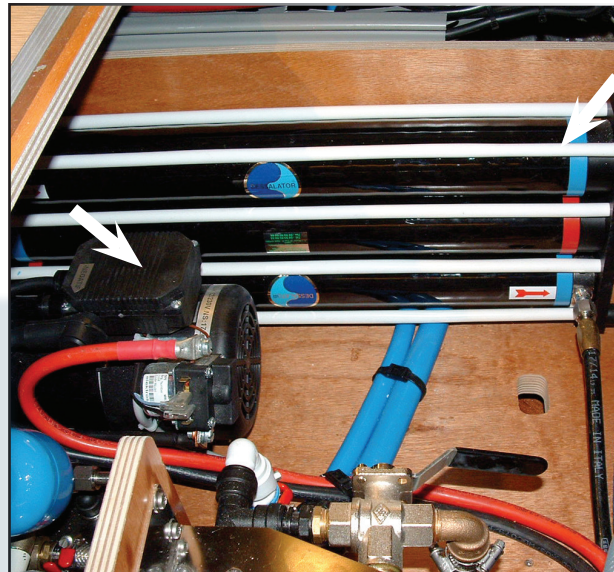

**THREE-WAY VALVE +  
SEA WATER SUPPLY VALVE**



### ■ WATERMAKER

The boat can be optionally equipped with a watermaker located in front of the bed in the port aft cabin.

#### **RECOMMENDATION**

The watermaker shall exclusively be used in clean waters.

### OPERATION

The watermaker functions with the generator on.

Open the seawater supply valve (access under the floor in front of the port aft cabin bed).

To switch on the watermaker:

- Check that its automatic breaker is switched on at the power busbar in the cupboard behind the switchboard in the starboard hull companionway is on.

- Switch the watermaker on via its adjacent control or via its remote control in the port companionway.

The watermaker circuit is equipped with a 3 channel valve to supply freshwater to the port or starboard tanks. This valve is in front of the watermaker. Check the fresh water level in the tanks when the watermaker is running.

The watermaker is provided with an automatic end of cycle rinsing function. Make sure the water pump is running when using the watermaker.

For the use and maintenance of the watermaker, please refer to its instruction guide.

## 6.3 Icemaker

### COCKPIT ICEMAKER

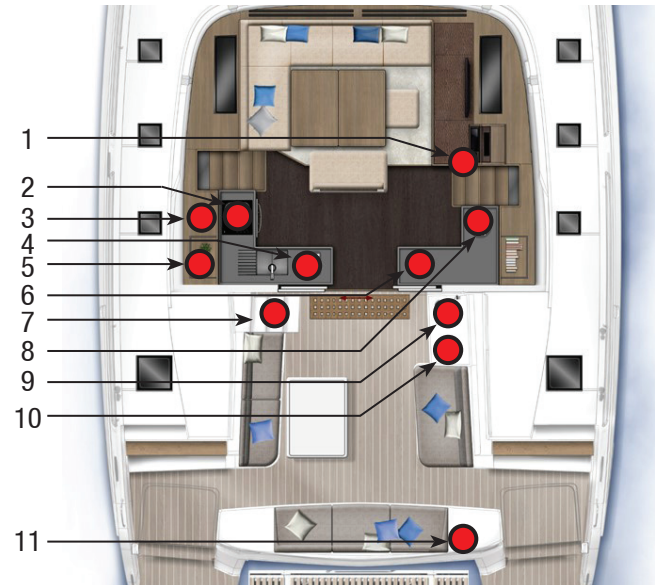

- 1 - 12 V / 220 V electrical panel.
- 2 - Gas hobs and oven.
- 3 - Gas valve.
- 4 - Dishwasher (option).
- 5 - Microwave oven (option).
- 6 - Drawer fridge.
- 7 - Locker for gas bottles.
- 8 - Refrigerator or freezer (option).
- 9 - Cockpit icemaker (option).
- 10 - Cockpit fridge (option).
- 11 - Plancha (option).

#### ■ COCKPIT ICEMAKER

The boat may optionally be fitted with an icemaker, located in the starboard cockpit cabinet.

Its water supply comes from the starboard tank.  
Open the freshwater valve located behind the icemaker.  
Turn on the switch at the bottom of the icemaker.

- Check that its automatic breaker is switched on at the Power busbar in the cupboard behind the switchboard in the starboard hull companionway is on.  
Ensure the switch of the port side water unit on the electrical panel on the chart table side is ON.

#### SUPPLY

Select the power source (generator or shore power supply number 1) from the left selector in the starboard hull companionway.

It is supplied with water coming from the fresh water system.

## 6.4 Dishwasher



### DISHWASHER FRESHWATER SUPPLY VALVE

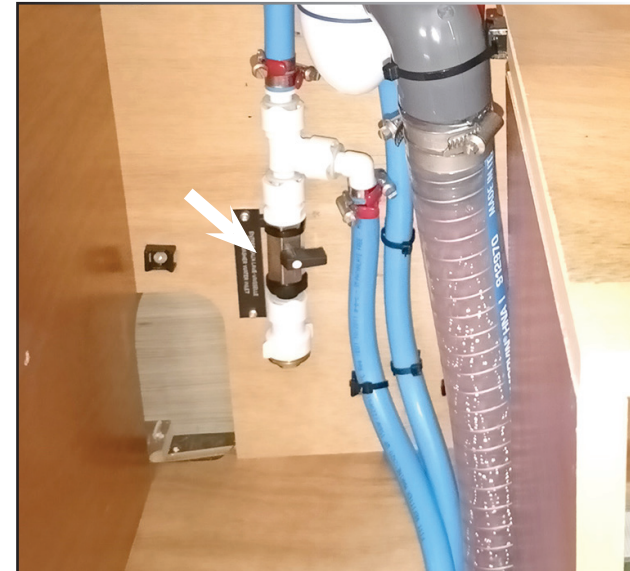

#### ■ DISHWASHER

The boat may be fitted with an optional dishwasher. The dishwasher is in the cabinet next to the sink. Its water supply comes from the freshwater circuit. Check the opening of its freshwater supply valve under the sink. It shares a drain with the sink.

- Check that its automatic breaker is switched on at the Power busbar in the cupboard behind the switchboard in the starboard hull companionway is on.

#### SUPPLY

Select the power source (generator or shore power supply number 1) from the left selector in the starboard hull companionway.

For the use and maintenance of the dishwasher, please refer to its instruction manual.

## 6.5 Refrigerators - freezer

**DRAWER REFRIGERATOR**



**DRAWER FREEZER**



**GANGWAY REFRIGERATOR**



### ■ REFRIGERATORS

The boat is equipped with a 190-litre refrigerator in the starboard saloon cabinet.

The boat can optionally be equipped with a draw freezer next to the standard refrigerator, with a second refrigerator (130 l) or freezer (110 l) in the port gangway.

The freezer provides negative cold capacity.

The boat can also be optionally equipped with a cockpit refrigerator (80 l), located under the starboard cabinet in the cockpit.

Once the 12 V on-board power supply is on, turn on the units using the cold unit switch on the electrical panel on the side of the chart table, then switch on the units with their thermostat knobs.

Defrost then drain these appliances before turning off the 12 V on-board circuit.

For instructions on use of these appliances, please refer to their instruction manuals.

## 6.6 Gas oven and hobs

GAS HOBS AND OVEN



GAS VALVES



### ■ GAS OVEN AND HOBS

The boat is equipped as standard with an gas oven and hobs.  
The gas valves are located in the cupboard under the oven.  
The gas cylinder is located in a port locker in the cockpit.

#### **RECOMMENDATION**

Shut the gas valves and the regulator tap when you do not use the gas oven and hobs.

Gas hob ignition is electric.  
The inverter that supplies ignition is automatically operated when the 12 V system on board is switched on.

The boat in her US version has a lectrovalve located in the bottles storage locker.  
Turn on the lectrovalve with its switch above the hob.

## 6.7 Microwave oven

### MICROWAVE OVEN



#### ■ MICROWAVE OVEN

The boat is fitted with an optional microwave located in the upper cabinet in the galley.

- Check that its automatic breaker is switched on at the Power busbar in the cupboard behind the switchboard in the starboard hull companionway is on.

#### SUPPLY

Select the power source (generator or shore power supply number 1) from the left selector in the starboard hull companionway.

For the use and maintenance of the oven, please refer to its instruction manual.

## 6.8 Cockpit plancha

51

### COCKPIT PLANCHA



#### ■ COCKPIT PLANCHA

The aft cockpit beam can optionally be fitted on its starboard side with a gas plancha. The gas cylinder (2.25 kg for Europe version, 4.54 kg for US version) supplying the plancha is stored in the locker accessible by rotating the plancha.

#### **CAUTION**

Make the necessary arrangements for maximum safety when using the plancha.

Do not close the plancha cabinet cover until the surface has cooled.

For the use and maintenance of the plancha, please refer to its instruction manual.



# LIFE ON BOARD - PRIVATE SPACES

---

7

**7.1 Head compartments**

**7.2 Toilets**

## 7.1 Head compartments

### OWNER'S HEAD COMPARTMENT



#### ■ SHOWER DOORS

In the 3 and 4-cabin versions, the shower rooms have a shower enclosure separated by a Plexiglas door.

#### **RECOMMENDATION**

After use, and when sailing, lock the shower doors in the closed position.

### WASTEWATER COLLECTION SYSTEM



#### ■ GREY WATERS

The grey water from the sinks (galley, cockpit) flow directly via through-hulls with valves.





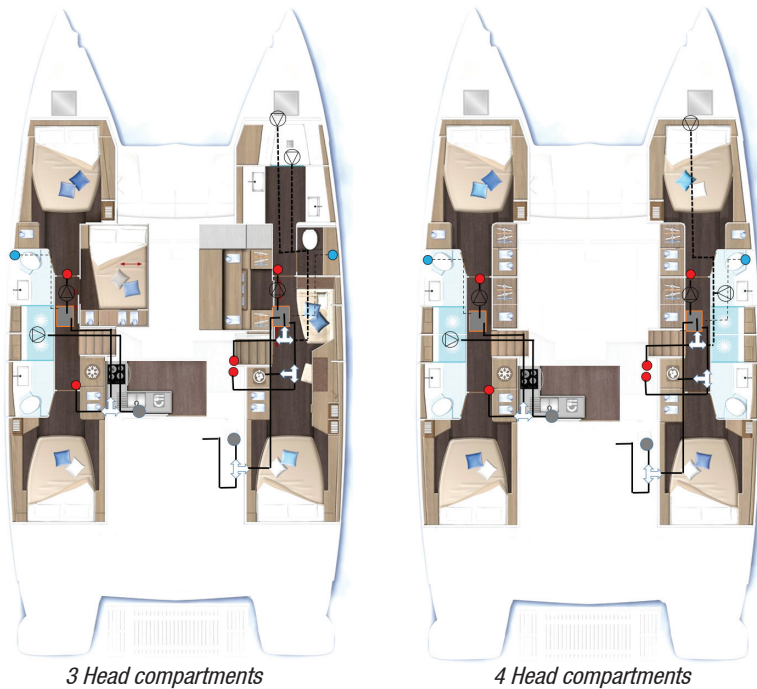

All wastewater from the head compartments (washbasins and showers) is collected in a collection tray under the shower and drained automatically to the gunwale by an electric pump.

The pumps are powered by the 12 V on-board circuit.

Please note: a valve is closed when its handle is perpendicular to the pipe and it is open when its handle is in line with the pipe.

## 7.1 Head compartments



-  Optional 120 L tanks
-  Grey water transfer pump
-  3-way valves
-  Through-hull drainage to the sea
-  Grey water intake fitting
-  Grey water flow circuit

### CONTROL PANEL FOR DRAINING GREY WATER TANKS



#### ■ GREY WATER TANK

The boat can be optionally equipped with two grey water tanks of 120 L each. Monitor the level of the grey water tanks via the touch control screen in the cupboard of the starboard hull companionway.

3-way valves allow the discharge of grey water directly to the sea without passing through the tanks, depending on the sailing area.

The 3-way valves are located:

- In the port aft cabin, under a hatch in the wardrobe (port side bathrooms, galley sink, dishwasher).
- In the locker of the cockpit starboard bench (cockpit sink).
- Under the floor in front of the starboard companionway (starboard bathrooms, washing machine).

Draining the tanks:

- Switch on the boat's 12 V circuit.
- In an authorised zone, press the switches on the control panel in the starboard companionway.

In a port equipped with an organic waste suction system:

- Insert the suction hose into the tank via the corresponding deck fitting (see locations on the above drawing).
- Start the pump of the suction system.

Regularly rinse the grey water holding tank.

## 7.2 Toilets

### MANUAL TOILETS



#### ■ MANUAL TOILETS

The boat is equipped as standard with 3 to 4 manual toilets depending on the layout version and black water tanks (one per hull).

It may be equipped with electric WCs.

#### USE OF MANUAL TOILETS

- Open the water inlet and drain valves.

To empty the toilet bowl:

- Set the control lever of the pump slantwise (FLUSH) and operate the pump.

To dry the toilet bowl:

- Set the lever back vertical (DRY) and operate the pump.

### SEAWATER INLET VALVE



In order to avoid clogging the toilets, use absorbent paper only and pump until the emptying hose is completely empty.

#### **RECOMMENDATION**

To prevent clogging, use only water-soluble toilet paper.

Caution: to avoid blockages, do not dispose of sanitary towels, panty liners or any other similar products in the toilets and black water tank.

- Regularly rinse the WCs with fresh water.

- Close the valves after each use.

## 7.2 Toilets

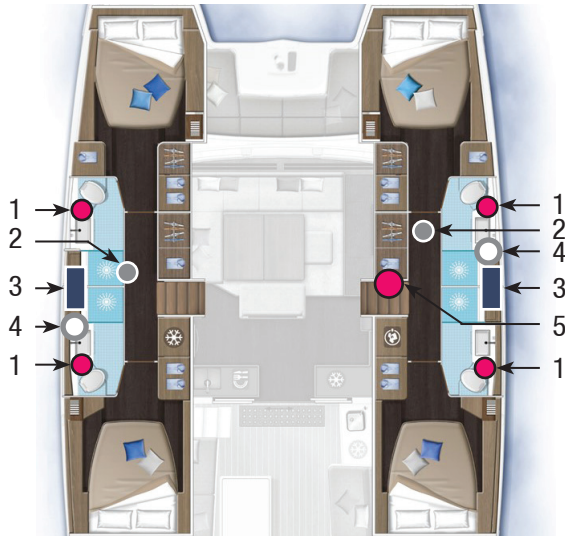

4-cabin version



3-cabin version

- 1 - Electric pump.
- 2 - Overboard discharge valve.
- 3 - Black water tank.
- 4 - Black water drain fitting.
- 5 - Operation of the freshwater unit.

### ELECTRIC TOILET + ALARM + ELECTRIC TOILET CONTROL



#### ■ ELECTRIC TOILET

The boat is equipped with 3 to 4 electric WCs according to the equipment version. Electric toilets use the on-board fresh water supply for flushing (about 0.6 litres per flush).

#### ■ USE OF ELECTRIC TOILETS

First ensure the 12 V circuit is on and the water unit switch on the dashboard is On.

One of the switches next to the toilets controls a water intake and outlet cycle.

The second switch is used to do a rinse cycle.

See page opposite for details on recommended use.

For the use and maintenance of the electric toilets, please refer to their instruction manuals.

## 7.2 Toilets

**BLACK WATER TANK**



**BLACK WATER TANK LEVEL**



**SEA DISCHARGE VALVE**



### ■ USE OF THE HOLDING TANKS

The tanks are accessed via the heads.

Monitor the level in the black water tanks via the access hatches in each black water tank.

Managing tank levels:

A visual alarm located next to the electric toilet controls lets the user know when the tank reaches its high level.

Make sure the drain valve of the tank is closed in order to avoid any inadvertent discharge (the valve is closed when the handle is perpendicular to the hose).

Draining the tanks:

- In an authorised area, open the drain valve.

### **CAUTION**

The tank drain valves **MUST** be opened before any drainage operation, and then closed again once the operation is finished.

## 7.2 Toilets

### BLACK WATER DRAIN FITTING



### PRINCIPLE OF THE VERTICAL BLACK WATER TANK

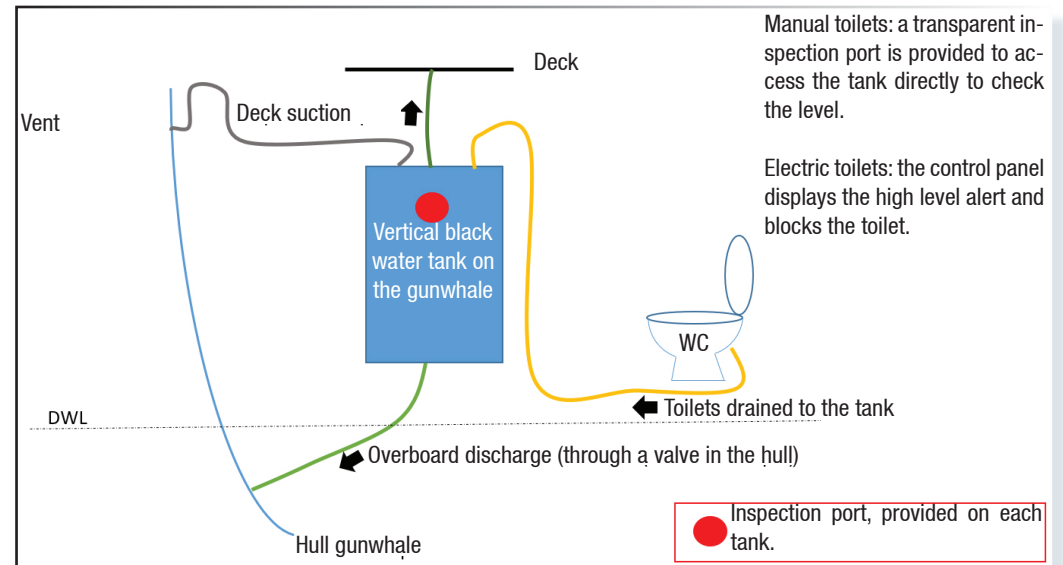

In a port equipped with an organic waste suction system:

- Insert the suction hose into the tank through the corresponding deck filler (see locations on the previous page).
- Start the pump of the suction system.

#### CAUTION

Use pumping systems at harbours or marinas to empty the holding tanks.

To respect the environment, please do not discharge your holding tank near the shore.

#### ■ CLEANING BLACK WATER TANKS

There is an increased risk of unpleasant smells the longer wastewaters remain in the tank.

- Do not wait for the tank to be full; empty the tank regularly and as soon as is possible.
- After emptying the tank, pour in approx. 5 litres of fresh water together with an appropriate detergent additive (available at ship chandlers).

One very simple method is to add soda crystals that clean and disinfect at the same time.

Before wintering the boat, rinse the tank thoroughly with fresh water, filling it up via the "WASTE" deck filler, then empty it completely.

#### DISINFECTION

- Disinfect the tank once a year by filling it up with a bleach and water mixture (ratio of 1 to 1000).



# ENERGY - ENGINE

---



**8.1 Batteries**

**8.2 Shore power sockets**

**8.3 Inverters**

**8.4 Generator**

**8.5 Electricity - Annexes**

**8.6 Motorization**

## 8.1 Batteries

### BATTERY BANK



### BATTERY CHARGERS



### 12 V BATTERY CHARGERS CIRCUIT BREAKERS

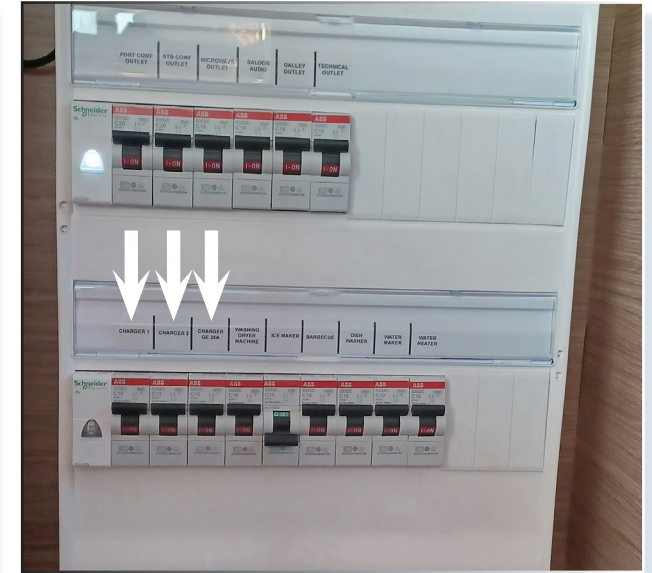

#### ■ BATTERIES

The battery bank supplying the boat with 12 V is located in the starboard engine compartment.

The 12 V circuit is switched on at the manual cut-out located in the starboard engine compartment.

Monitor the level of the batteries via the touch control screen in the cupboard on the side of the chart table.

#### ■ BATTERY RECHARGING

Charging the battery bank is done via two coupled alternators (12 V / 125 A) or via a battery charger (220 V / 12 V - 60 A).

The boat can, according to the chosen finish, be equipped with an additional 110 V - 220 V / 12 V - 40 A charger.

The 12 V chargers are located in the starboard engine compartment.

A third charger (220 V / 12 V - 25 Amp) delivered with the generator option, recharges the 12 V generator battery.

#### OPERATION

Ensure their circuit breakers on the power bus in the cupboard behind the electrical panel in the starboard hull companionway are on.

Select the power source (generator or shore power supply number 1) from the left selector in the starboard hull companionway.

Note: the battery chargers can remain in operation even when the boat is not energized in 12 V.

## 8.2 Shore power sockets

### SHORE POWER SOCKETS



#### ■ SHORE POWER SOCKETS

The boat is equipped with a shore power connection located in the aft starboard cockpit skirt.

It powers the 220 V circuit and the battery chargers.

A second shore power connection for the air conditioning is installed nearby if the boat is equipped with the air conditioning option.

#### **CAUTION**

Before using the shore power sockets, imperatively check the shore power is 32 Amp (50 Amp version for the US).

Before you plug in or unplug the boat / shore power supply cable, switch off the shut off device connected to the shore supply.

### SHORE POWER SOCKETS CIRCUIT BREAKERS

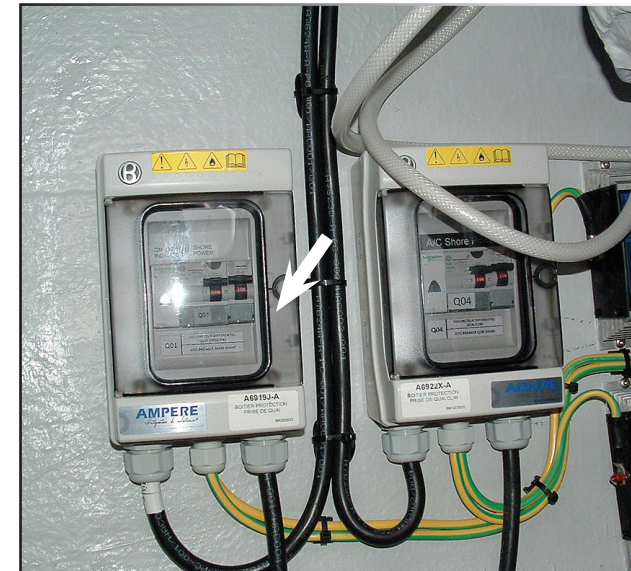

Connect the boat / shore power supply cable in the boat before connecting it to the shore supply socket.

Unplug the boat / shore supply cable on shore first.

#### **DANGER**

Never let the end of the boat/shore supply cable hang in the water, the result may be an electric field liable to hurt or kill the swimmers nearby.

Close the protecting cover of the shore supply socket when you do not use the plug. The shore power sockets are protected by circuit breakers located in the starboard engine compartment.

## 8.3 Inverters

### 12 V / 220 V - 150 W INVERTER



- 1 - Generator.
- 2 - 12 V / 220 V - 2000 VA inverter.
- 3 - 12 V / 220 V - 150 W inverter.
- 4 - 220 V / 12 V 60 Amp battery charger.
- 5 - 220 V / 12 V 40 Amp battery charger.
- 6 - On-board battery banks.
- 7 - On-board battery banks.

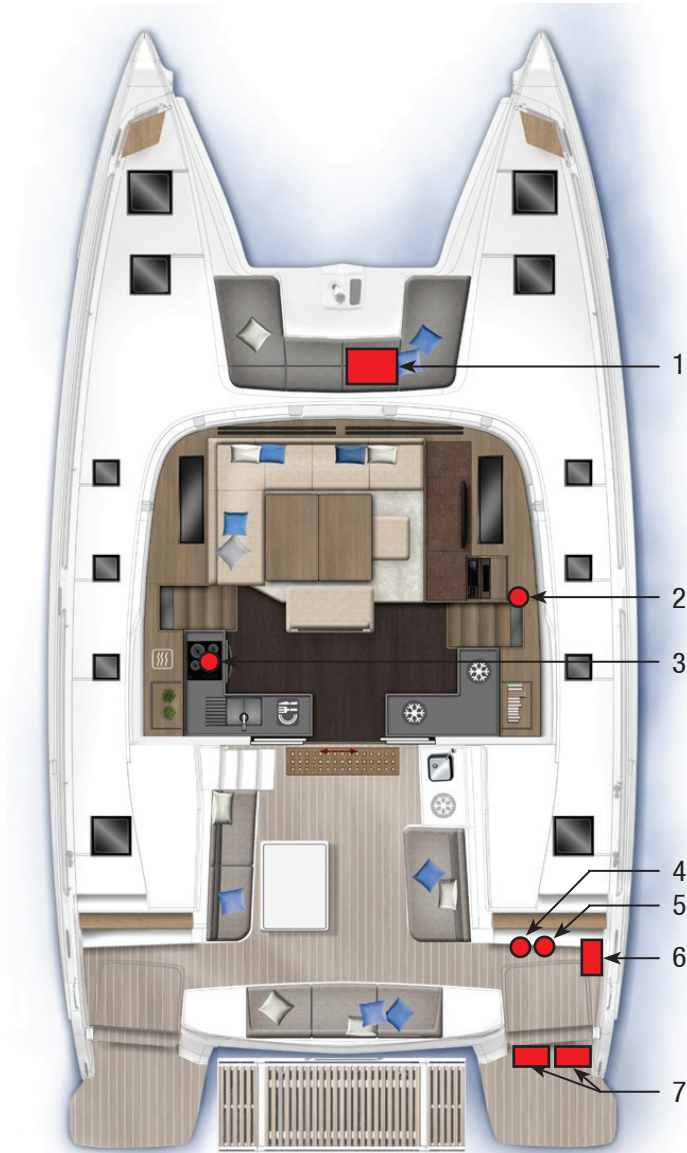

#### ■ 12 V / 220 V - 150 W INVERTER

When the boat is not equipped with an inverter 12 V / 220 V / 2000 VA, or has an optional inverter 110 V, the boat is equipped with a 12 V / 220 V - 150 W inverter for ignition of the gas hobs and oven (piezo-electric).

The inverter is located in the cupboard under the oven.

It is switched on automatically when the 12 V system is on.

## 8.3 Inverters

12 V / 220 V - 2000 VA INVERTER



CIRCUIT BREAKER  
12 V / 220 V - 2000 VA INVERTER



### ■ 12 V / 220 V – 2000 VA INVERTER

The boat is equipped as standard with a 12 V / 220 V - 2000 VA inverter located behind the electric panel in the starboard companionway.

The inverter supplies power to the on-board sockets.

### **RECOMMENDATION**

Use with caution the biggest electrical-consuming devices supplied with 220 V (e.g. microwave) when they depend on the inverter. Check the battery charge during use of the inverter.

The inverter operates once the 12 V on-board circuit is turned on.

If it does not work, check the circuit-breaker under the inverter.

## 8.4 Generator

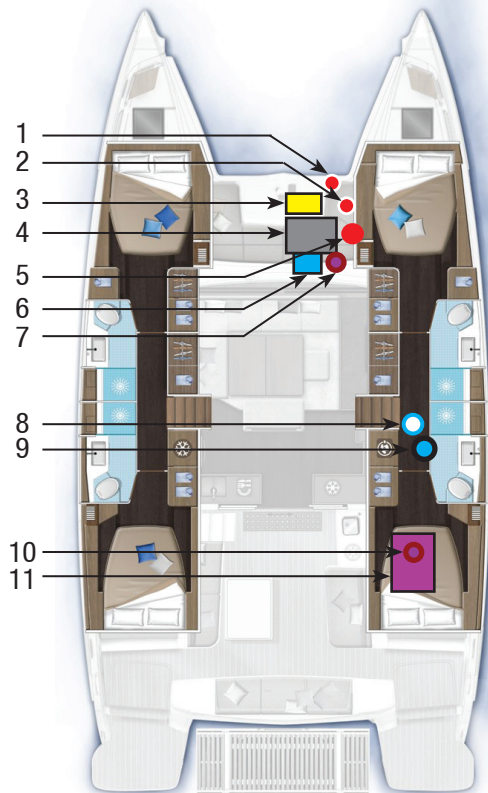

- 1 - Generator cut-out.
- 2 - Generator automatic breakers.
- 3 - Generator ignition battery.
- 4 - Generator.
- 5 - 12 V battery charger.
- 6 - Water / gas separator.
- 7 - Fuel filter.
- 8 - Sea water filter.
- 9 - Sea water inlet valve.
- 10 - Fuel / generator stop pull handle.
- 11 - Fuel tank.

### GENERATOR



### CIRCUIT BREAKERS + CHARGER + FUEL FILTER



#### ■ GENERATOR / 12 V CIRCUIT

#### ● 12 V CIRCUIT

The 12 V battery powering the generator is located in the foredeck service room. The battery is charged either via the generator alternator or via a 220 V / 12 V - 25 Amp battery charger in the foredeck service room.

The battery charger can work when connected to the shore power socket. Ensure the circuit breaker on the POWER bus in the cupboard behind the switchboard in the starboard hull companionway is on.

Select the power source (Shore number 1) from the left selector in the starboard hull companionway.

## 8.4 Generator

**AUTOMATIC BREAKER**



**WATER FILTER +  
GENERATOR WATER INLET**

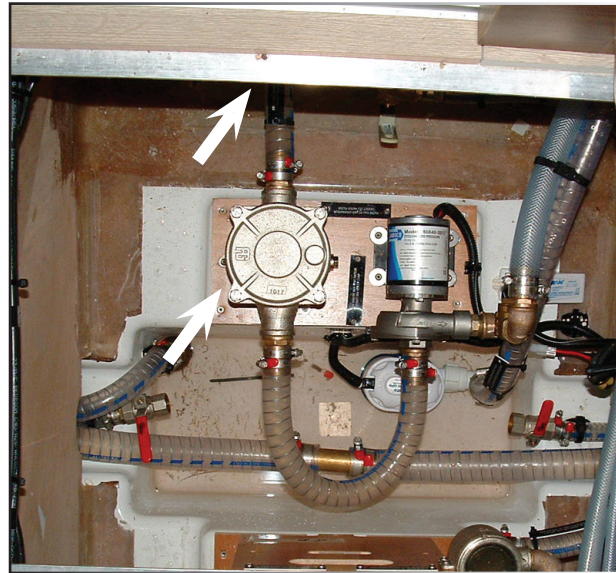

**GENERATOR CONTROL**



### ● GENERATOR

The generator is located in the service room of the foredeck. It is used to charge the batteries via the charger and to supply 220 V on board.

### OPERATION

After switching ON the circuit breakers in the starboard foredeck locker, the generator is started either on the generator or via its control on the electrical panel in the cupboard on the side of the chart table.

Be sure to open the fuel tap (access under the starboard aft cabin berth) and its sea-water cooling valve (access under the floor of the starboard gangway).

For the use and maintenance of the generator, please refer to its instruction manual.

## 8.5 Electricity - Annex 1

■ The power busbars in the starboard companionway supply the various electrical equipment of the boat.  
This equipment is protected by fuses.

**DANGER**

Before working on a power busbar, switch OFF the 12 V on-board circuit.

**POWER BUSBAR  
STARBOARD COMPANIONWAY**

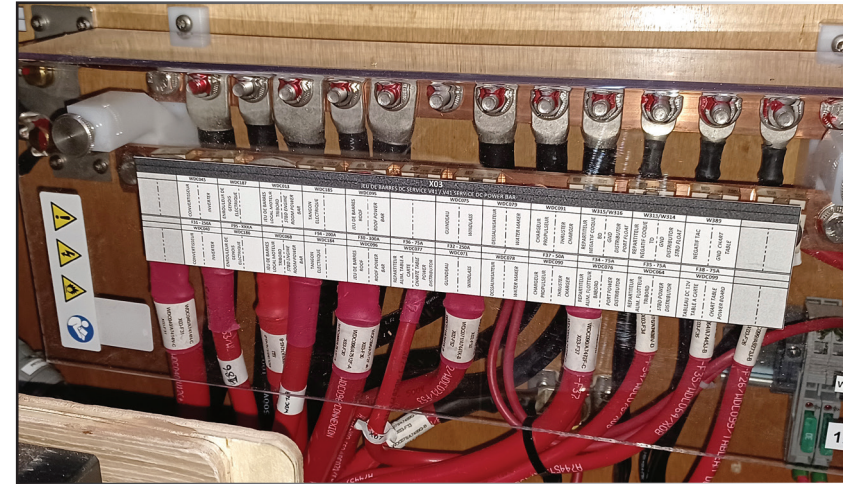

**CONNECTING CABLES  
TO THE SERVICE BUSBAR**

X03 JEU DE BARRES DC SERVICE V41 / V41 SERVICE DC POWER BAR											
WDC045	WDC187	WDC013	WDC185	WDC095		WDC075	WDC079	WDC091	W315/W316	W313/W314	W389
CONVERTISSEUR ----- INVERTER	ENROULEUR DE GENOIS ELECTRIQUE	JEU DE BARRES LOCAL MOTEUR TRIBORD STBD ENGINE ROOM POWER BAR	TANGON ELECTRIQUE	JEU DE BARRES ROOF ROOF POWER BAR		GUINDEAU ----- WINDLASS	DESSALINISATEUR ----- WATER MAKER	CHARGEUR PROPULSEUR THRUSTER CHARGER	REPARTITEUR NEGATIF COQUE BD GND DISTRIBUTOR PORT FLOAT	REPARTITEUR NEGATIF COQUE TD GND DISTRIBUTOR STBD FLOAT	NEGATIF TAC ----- GND CHART TABLE
F31 - 250A	F95 - 200A	/	F94 - 200A	F30 - 300A	F36 - 75A	F32 - 250A	/	F37 - 50A	F34 - 75A	F35 - 75A	F38 - 75A
WDC040	WDC186	WDC068	WDC184	WDC096	WDC077	WDC071	WDC078	WDC090	WDC076	WDC064	WDC099
CONVERTISSEUR ----- INVERTER	ENROULEUR DE GENOIS ELECTRIQUE	JEU DE BARRES LOCAL MOTEUR TRIBORD STBD ENGINE ROOM POWER BAR	TANGON ELECTRIQUE	JEU DE BARRES ROOF ROOF POWER BAR	REPARTITEUR ALIM. TABLE A CARTE CHART TABLE POWER DISTRIBUTOR	GUINDEAU ----- WINDLASS	DESSALINISATEUR ----- WATER MAKER	CHARGEUR PROPULSEUR THRUSTER CHARGER	REPARTITEUR ALIM. FLOTTEUR BORD PORT POWER DISTRIBUTOR	REPARTITEUR ALIM. FLOTTEUR TRIBORD STBD POWER DISTRIBUTOR	TABLEAU DC 12V TABLE A CARTE ----- CHART TABLE POWER BOARD

## 8.5 Electricity - Annex 1

■ The power busbars in the starboard engine compartment supply various electrical equipment of the boat.  
This equipment is protected by fuses.

### **DANGER**

Before working on a power busbar, switch OFF the 12 V on-board circuit.

### POWER BUSBAR STARBOARD ENGINE COMPARTMENT

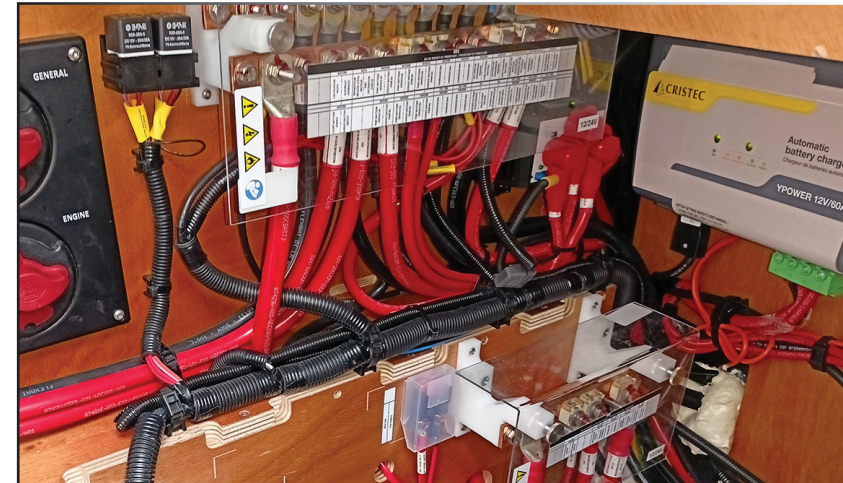

### CABLE CONNECTIONS TO THE SERVICE BUSBAR

X01 JEU DE BARRES DC PRIORITAIRE / PRIORITARY DC POWER BAR											
WDC093	W371/W003-004	WDC002	WDC008	WDC012	WDC029	WDC067	WDC058	WDC019	WDC062/WDC107	WDC038/WDC117	WDC013
CALCULATEUR PILOTE AUTOPILOT HYDRAULIC	REPART NEG LOCAL MOTEUR / EV PLANCHA / GND DISTRIB STDB ER / EV PLANCHA	PARC BATTERIE SERVICE #1 BATTERY PARK #1	PARC BATTERIE SERVICE #2 BATTERY PARK #2	PARC BATTERIE SERVICE #3 BATTERY PARK #3	CHARGEUR 60A CHARGER 60A	CHARGEUR 40A CHARGER 40A	BATTERIE DE DEMARRAGE TRIBORD STBD STARTING BATTERY	BATTERIE DE DEMARRAGE BORD PORT STARTING BATTERY	TENDER LIFT OU BOSSOIR ELECTRIQUE TENDER LIFT OR ELECTRICAL DAVIT	PANNEAUX SOLAIRES SOLAR PANELS	JEU DE BARRES TABLE A CARTE CHARTE TABLE POWER BAR
COUPE BATTERIE SERVICE SERVICE BATTERY SWITCH		PARC BATTERIE SERVICE #1 BATTERY PARK #1	PARC BATTERIE SERVICE #2 BATTERY PARK #2	PARC BATTERIE SERVICE #3 BATTERY PARK #3	CHARGEUR 60A CHARGER 60A	CHARGEUR 40A CHARGER 40A	BUIZZER SYSTEME ASSECHEMENT BILGE PUMP BUZZER	EXTRACTEUR LOCAUX MOTEUR EXTRACTOR ENGINE AREA	REPARTITEUR DE CHARGE TD STBD CHARGE COMBINERS	REPARTITEUR DE CHARGE BD PORT CHARGE COMBINERS	PANNEAUX SOLAIRES SOLAR PANELS
					F11 - 75A WDC028	F12 - 50A WDC066	2A	5A	F13 - 125A WDC026	F14 - 125A WDC027	F15 - 100A WDC037/WDC116

X02 JEU DE BARRES DC POSITIF SERVICE / POSITIVE SERVICE DC POWER BAR					
	2A	F20 - 50A	F21 - 175A	F63 - 100A	F22 - 300A
WDC031	W001	WDC092	WDC061	WDC103	WDC068
COUPE BATTERIE SERVICE SERVICE BATTERY SWITCH	EV PLANCHA COCKPIT EV COCKPIT PLANCHA	CALCULATEUR PILOTE AUTOPILOT HYDRAULIC	TENDER LIFT TENDER LIFT	BOSSOIR ELECTRIQUE ELECTRICAL DAVIT	JEU DE BARRES TABLE A CARTE CHARTE TABLE POWER BAR

X04 JEU DE BARRE DC NEGATIF ROOF / NEGATIVE ROOF DC POWER BAR						
WDC057	WDC053	WDC049	WDC044	W153/154/155/156	WDC60	
LINE DRIVER LINE DRIVER	WINCH TRIBORD STBD WINCH	WINCH BORD PORT WINCH	DRISSE GV MAINSAIL WINCH	REPARTITEURS NEGATIF ROOF ROOF GND DISTRIBUTORS	ALIMENTATION JEU DE BARRE ROOF ROOF POWER BAR	

## 8.5 Electricity - Annex 2



- 1 - Saloon fuses.
- 2 - Chart table power busbar.
- 3 - Port hull + port cabins fuses.
- 4 - Starboard hull + starboard cabins fuses.
- 5 - Roof fuses.
- 6 - Starboard engine compartment power busbars.

### SALOON FUSES

CALIBRE	ETIQUETTE
30A	ALL OFF LIGHTS RELAY
30A	ALL OFF FRIDGE RELAY
30A	ALL OFF ELECTRONIC RELAY
15A	RADIO PLAYER
20A	TABLE LIFT

CALIBRE	ETIQUETTE
10A	PORT READING LIGHT/FAN
10A	STBD READING LIGHT/FAN
5A	PORT BATHROOM LIGHTS
5A	STBD BATHROOM LIGHTS
15A	PORT LIGHTING MODULE
15A	STBD LIGHTING MODULE
15A	ROOF LIGHTING MODULE
15A	CHART TABLE LIGHTING MODULE
2A	CHART TABLE READING LIGHT

CALIBRE	ETIQUETTE
15A	FRIDGE 190L
15A	OPT FRIDGE
15A	OPT PORT HULL FRIDGE
15A	OPT COCKPIT FRIDGE

### SALOON FUSES

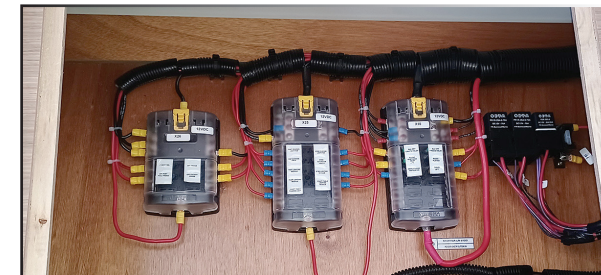

# 8.5 Electricity - Annex 2

## STARBOARD HULL FUSES

## PORT HULL FUSES

## ROOF FUSES

PORT FLOAT	FUSIBLES - EQUIPEMENTS COQUE BD FUSE - PORT FLOAT EQUIPMENT							
NAME	F01	F02	F03	F04	F05	F06	F07	F08
DESIGNATION	PUMP WASHER DECK		GREY WATER TANK PUMP (OPTIONNAL)	MONITORING BLOC 7#1	SEA WATER PUMP	STOVE & OVEN PIEZZO INVERTER	WC SEA WATER PUMP (optionnal)	GAS SOLENOID VALVE (optionnal US)
CALIBRE	10A		10A	5A	10A	20A	15A	2A

STBD FLOAT	FUSIBLES - EQUIPEMENTS COQUE TD FUSE - STBD FLOAT EQUIPMENT							
NAME	F01	F02	F03	F04	F05	F06	F07	F08
DESIGNATION	PUMPS SWITCH GREY WATER TANKS		GREY WATER TANK PUMP (OPTIONNAL)	MONITORING BLOC 7#0	SALOON FANS			
CALIBRE	2A		10A	5A	1A			

PORT FLOAT	FUSIBLES - EQUIPEMENTS CAB BD FUSE - PORT FLOAT CABIN EQUIPMENT							
NAME	F01	F02	F03	F04	F05	F06	F07	F08
DESIGNATION	WC - A10		WC - A50	GREY WATER PUMP - A50 - V3/V4	GREY WATER PUMP - A30 - V6T	GREY WATER PUMP - A10 - V6T		
CALIBRE	20A		20A	10A	10A	10A		

STBD FLOAT	FUSIBLES - EQUIPEMENTS CAB TD FUSE - STBD FLOAT CABIN EQUIPMENT							
NAME	F01	F02	F03	F04	F05	F06	F07	F08
DESIGNATION	WC - A20		WC - A60	HIFI - C60	GREY WATER PUMP - A60 - V6T	GREY WATER PUMP - A40 - V6T / FWD PEAK	GREY WATER PUMP - A20 - V3/V4	WC - FRONT STBD
CALIBRE	20A		20A	15A	10A	10A	10A	20A

CALIBRE	ETIQUETTE
2A	VHF HANDSET
10A	VHF
5A	AIS
3A	CODE 0 FURLER SWITCH
5A	TV ANTENNA
5A	THRUSTER COMMAND
10A	CHAIN COUNTER
5A	WINDLASS REMOTE
5A	PUSH UP LIGHT
5A	USB
3A	GENOA FURLER SWITCH
30A	ELECTRONIC

CALIBRE	ETIQUETTE
5A	PORT REAR CAMERA
10A	SEATALK NETWORK
5A	STBD REAR CAMERA
15A	CHART PLOTTER
10A	RADAR
5A	HUB

## 8.6 Motorization

### ACCESS TO ENGINES



- 1 - Fuel gauge.
- 2 - Fuel tank.
- 3 - Fuel valve.
- 4 - Starboard and on-board engine battery cut-out switches.
- 5 - Sea water filter.
- 6 - Fuel filter.
- 7 - Engine.
- 8 - Deck filler.
- 9 - Engine water inlet valve.
- 10 - 12 V battery.
- 11 - Port engine battery and coupling cut-out.

### ■ ACCESS TO ENGINES

You have access to the engines through the transom extension hatches.

### RECOMMENDATION

Stop the engines before opening the hatches.

If it is necessary to intervene when an engine is running:

- Stay away from belts and mobile parts.
- Beware of loose clothing, long hair, rings etc. (risk of entanglement).
- Wear suitable clothing (gloves, hats etc.).

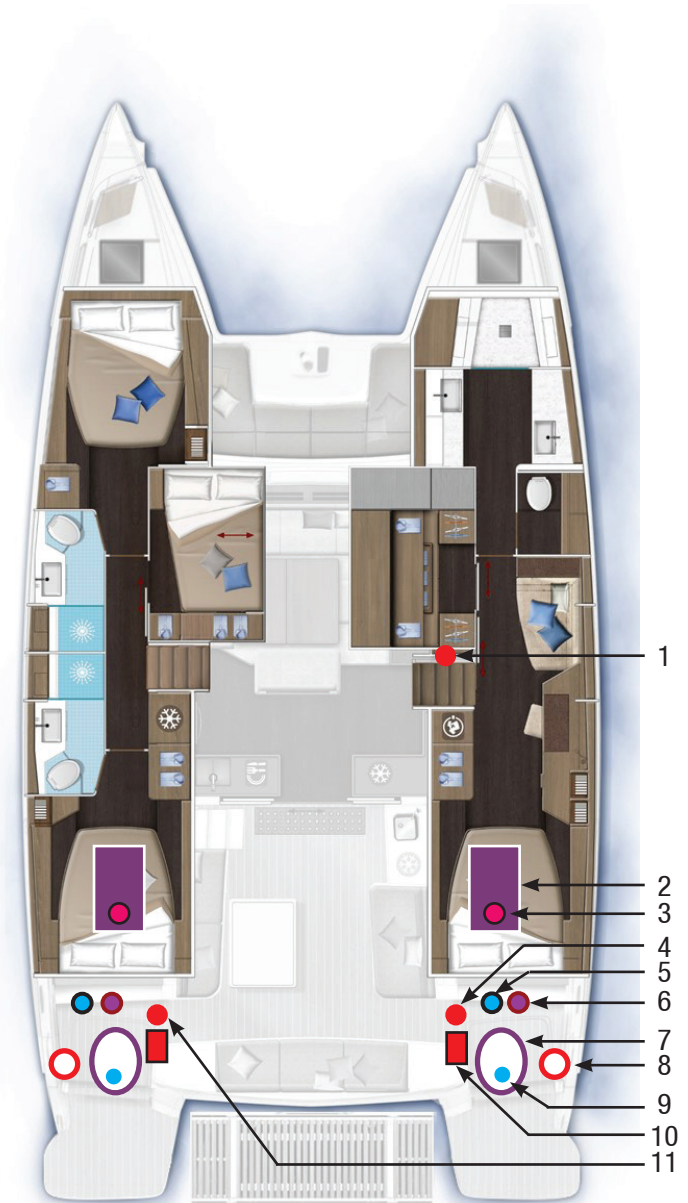

## 8.6 Motorization

ENGINE COMPARTMENT VENTILATOR



ENGINE WATER INLET

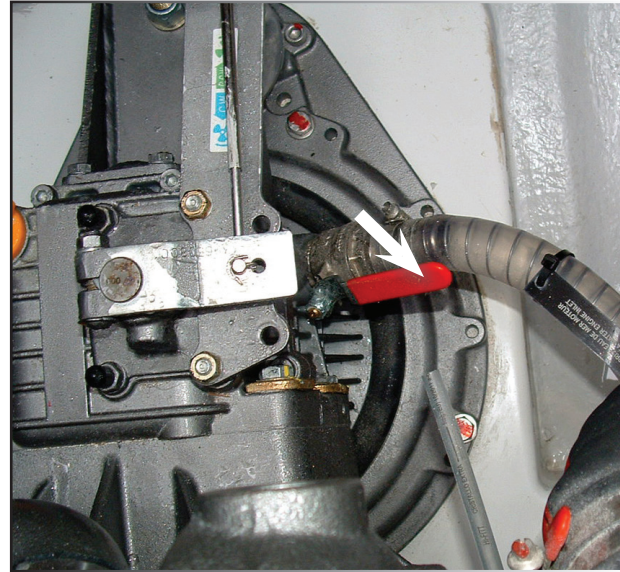

SEA WATER FILTER

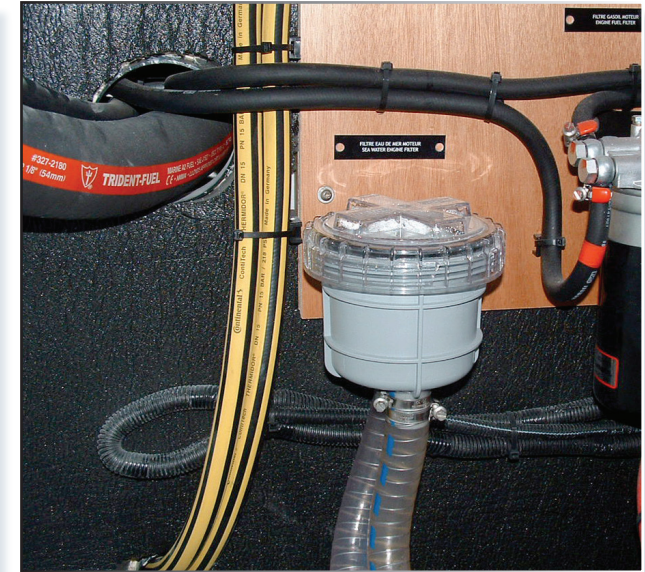

### ■ VENTILATION OF THE ENGINE BILGES

The engine compartment ventilators start up automatically as soon as the engines start.

### ■ ENGINE COOLING

The engine water inlets (in the engine rooms) must be open before starting the engines.

Always check immediately after starting the engines if water is expelled with the exhaust gases.

If water does not flow out:

- Stop the engine immediately.
- Check the valves are open.
- Check the cleanliness of the filters.

Keep the strainers of the engine water inlet valves as clean as possible.

Brush the strainers when the boat is careened.

Be careful: do not cover the strainers with antifouling paint.

Close the water inlet valves if the boat is left unattended for a long period of time. Inspect and clean the water filters regularly.

## 8.6 Motorization

### CONTROL TOUCH SCREEN CHOICE OF GAUGE TO READ

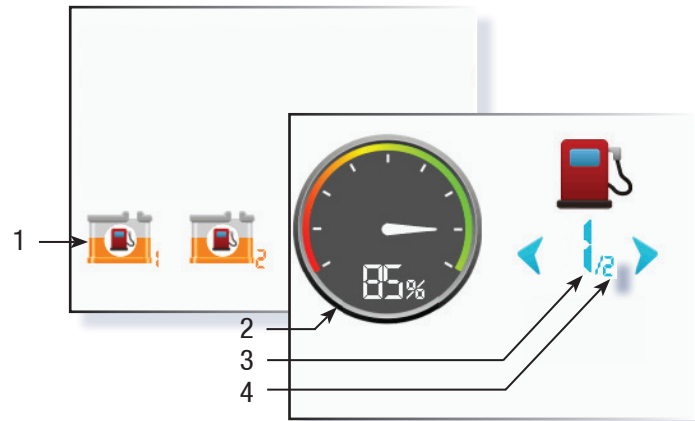

- 1 - Access to tanks gauges.
- 2 - Tank level.
- 3 - Tank number.
- 4 - Number of tanks on board.

#### ■ FUEL TANKS

The boat is equipped as standard with two 520-litre tanks located under the berths of the aft cabins.

Their gauge can be viewed on the control touch screen on the side of the chart table. They are filled separately.

The fuel valves are accessible on the tanks.

### DECK FILLERS



#### ■ FILLING THE FUEL TANKS

Fill the fuel tanks using the two fillers, located to port and starboard of the cockpit. Open and close the filler caps with the right key.

To prevent any handling mistake, never fill the water and fuel tanks at the same time. During filling, avoid handling contaminants near the fillers.

#### **DANGER**

Stop the engines and do not smoke or make telephone calls near fillers while filling the fuel tanks.

## 8.6 Motorization

FUEL VALVES

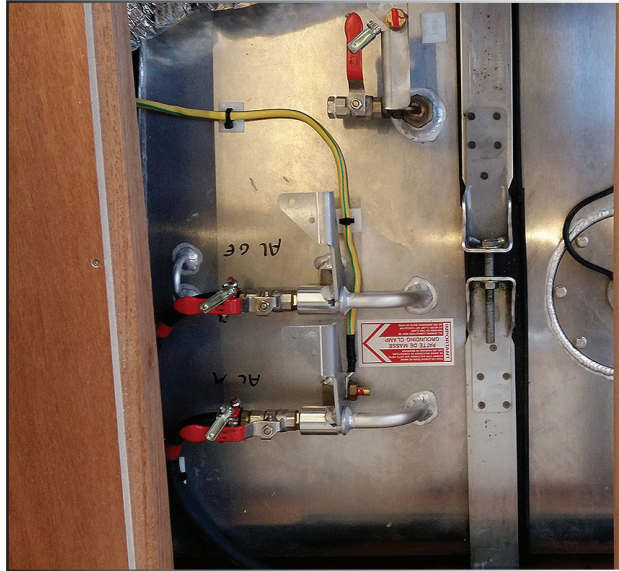

FUEL FILTER



### ■ FUEL TANKS MAINTENANCE

Regularly check the O rings of the fillers for good condition (to prevent water from entering the tanks).

Do not close the fuel valves between uses (except for prolonged absence).

Keep the fuel tanks as full as possible (to avoid condensation).

Every year check the fuel system for condition (hoses, valves, etc.).

Ask a professional to carry out any works on the damaged parts of the fuel system.

Nota: the capacity of the tanks (that is indicated in the page SPECIFICATIONS) may be not completely useable according to the trim and load of the boat.

Always keep 20% fuel as a reserve.

### ■ FUEL FILTER

In order to prevent any water infiltration, the fuel runs through two filters: The first one is on the pipe that links the tank to the engine (designed as a water decanter and pre-filter), the second one is an integral part of the engine (designed to filter fuel finely).

To know when you have to intervene and how frequently you have to change them, please refer to the engine instruction guide.

Drain it by undoing the knurled screw on the base of the decantation bowl (but do not remove it).

Allow to flow into a box till the fuel looks clean.

Do it several times a year.

Change the pre-filter at least once a year (access to it when you remove the bowl).



# SAFETY ABOARD

---

# 9

**9.1 Prevention**

**9.2 Safety equipment**

**9.3 Gas system**

**9.4 Fire prevention**

**9.5 Bilge pumping**

## 9.1 Prevention

### ■ CREW

For your own safety and your crew's, you shall respect some basic principles:

- Before you sail, check the different components of your safety equipment, their location, their expiry dates.
- Check the location and validity of the official documents as well.
- Inform the crew where the safety equipment is, how it works and the elementary safety procedures to follow.

When sailing, always be able to indicate your precise position.

In case an incident on board should happen and help be asked, this will be the very first question you will be asked.

#### **RECOMMENDATION**

Equip the children (and depending on the weather, the whole crew as well) with life jackets or harnesses.

#### **CAUTION**

Do not exceed the number of persons indicated in Chapter SPECIFICATIONS.

If you do not take the number of persons into account, the combined weight of the persons and equipment should never exceed the maximum load recommended by the builder.

### ■ THE BOAT

For good prevention and to feel confident to successfully face the possible risks on board (fire, leak), learn to recognise and locate the various elements which might be the cause of these risks as well as the equipment to cope with them.

Risk of fire:

- Electrical circuit (Chapters 1, 9.4 and 11.4)
- Gas system (chapter 9.3)
- Engines (Chapters 2.3, 8.6 and 9.4)

Risk of leak:

- Water systems (chapter 9.4)

#### **RECOMMENDATION**

In emergency situation, it is essential to be able to locate quickly all the appropriate safety equipments.

#### **RECOMMENDATION**

Always close the deck hatches and portholes before sailing.

### ■ MANOEUVRES

- Know where your crew members are and inform them before any manoeuvre.
- Perform deck manoeuvres carefully and always wear shoes.

### ■ ENGINES

- Systematically stop the engines before you dive or swim next to the boat.
- Never try to free a fishing net or a piece of rope that is caught on a propeller when the latter is rotating.

### ■ TOWING

If you have to tow another boat, tow her at a reduced speed and as smoothly as you can.

Be particularly careful when throwing or catching the towing line (It may catch on the propellers).

In case of failure of the hydraulic helm system, operate the circuit breaker at the rear of the port side engine hold to switch the system to the on board electric circuit.

### ■ VISIBILITY

The visibility from the wheel station may be reduced or obstructed due to important angles because of the trim of the boat or because of other factors related to one (or more) of the following conditions:

- Load and load distribution.
- Speed.
- Sea conditions, rain, spray.
- Darkness and fog.
- Lights on, inside the boat.
- Position of the upper and lateral awnings.
- Position of the upper and side awnings.

- Persons or removable equipments in the helmsman's field of visibility.  
Take into account all these parameters when sailing.

The international regulations for preventing collisions at sea (COLREG) and rules relative to courses make mandatory a permanent and proper observation and the respect of priority.

## 9.2 Safety equipment



- 1 - Manual bilge pump.
- 2 - Emergency tiller cover.
- 3 - Liferaft compartment.
- 4 - Emergency tiller compartment.
- 5 - Extinguisher.
- 6 - Lifbuoy location.
- 7 - .....
- 8 - .....
- 9 - .....
- 10 - .....
- 11 - .....
- 12 - .....

Some elements do not have a pre-determined location for them.  
Fill-in this plan according to your boat's safety equipment.

Before you sail, list the compulsory safety equipments.

**CAUTION**

The list of the compulsory safety equipments corresponds to a certification category, a design category as well as to the regulations in the country where the boat is registered.

**CAUTION**

Regularly check the safety equipments are in good working order.  
Follow the service programme without fail.

## 9.2 Safety equipment

LOCATIONS OF LIFERAFTS



LIFERAFT COMPARTMENT



LIFERAFTS ACCESS PANELS LOCKING SYSTEM



### ■ LIFERAFTS

The liferafts are located in the aft beam.

In the event of a rollover, remove the rings and push the pins to release the liferaft access panels.

Equip your boat with liferafts according to the regulations of the country where the boat is registered.

### **RECOMMENDATION**

Before you sail to sea, carefully read the launching instructions on the liferaft.

You shall use the liferaft only if all else fails.

## 9.2 Safety equipment

**EMERGENCY TILLER**



■ **EMERGENCY TILLER**

An emergency tiller is located in the port engine hold. This must remain easily accessible. It is designed to overcome a helm failure and can only be used to sail at a reduced speed.

**INSTALLATION**

- Use a winch handle and unscrew one of the tiller covers situated on one of the aft transom extensions.
  - Fit the emergency tiller into the rudder shaft, making sure that it is inserted properly.
  - Turn the cylinder valve in the engine compartment on the side concerned to the bypass position.
- The rudder is then isolated from the steering system.

**HYDRAULIC HELM CYLINDER  
STANDARD POSITION**

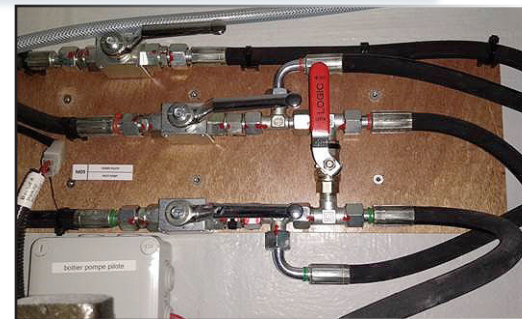
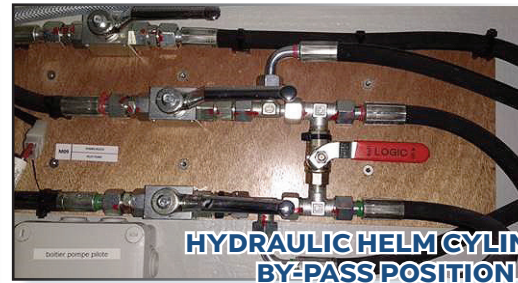

**MANHOLE PANEL**



■ **ROLLOVER**

Two “manhole” panels are provided in the gangways of each hull.

A hammer to break the glass is placed above each panel.

## 9.3 Gas system

**GAS BOTTLES LOCKER**



**BUBBLE LEAK DETECTOR**



**LEAK DETECTION PRESSURE GAUGE (US VERSION)**



### ■ GAS CIRCUIT

A locker at the port forward cockpit is designed to hold the gas bottle (13 kg). The circuit opening / closing valves are located in the cupboard under the oven. The US version of the boat has a electrovalve in the gas bottles storage locker. Switch on the electrovalve using its switch above the hob (electrovalve fuse in the port hull).

### **RECOMMENDATION**

Close the gas valves and turn off the regulator tap when the hobs and oven are not in use.

### GAS LEAK DETECTION

The gas circuit is equipped with a leak detection system. Standard version: a bubble leak detector is installed on the circuit after the regulator in the bottle storage locker.

When the gas bottle is open (system pressurised) and the valve under the appliance is closed, press the red button on the detector.

If nothing happens, the circuit is sealed.

The appearance of bubbles in the liquid of the detector indicates a leak in the gas circuit.

US version: a pressure gauge is installed on the circuit after the regulator in the bottle storage locker.

When the bottle is open (system pressurised) and the valve under the appliance is closed, the pressure on the pressure gauge must remain constant.

If the pressure drops it means that there is a leak in the gas circuit.

### **DANGER**

In case of a leak, immediately turn off the gas circuit. Call a professional to repair the gas system.

## 9.4 Fire prevention



- 1 - Emergency exit.
- 2 - Location of the extinguisher (not supplied).
- 3 - VHF location.
- 4 - Location of the smoke detector.
- 5 - Distress flares.
- 6 - First aid kit.

- 7 - .....
- 8 - .....
- 9 - .....
- 10 - .....
- 11 - .....
- 12 - .....
- 13 - .....
- 14 - .....
- 15 - .....

Some elements do not have a pre-determined location for them.  
Fill-in this plan according to your boat's safety equipment.

## 9.4 Fire prevention

The boat is delivered without fire extinguishers.

Be sure:

- Fit the boat with extinguishers in compliance with the regulations of the country where the boat is registered, in particular, hose-type extinguishers in the aft cabins.
- To have the extinguishers checked in accordance with the instructions given.
- To refill or replace the extinguishers with similar equipment if the extinguishers have been used or are out of date.
- Make sure that the extinguishers are accessible when people are on board.
- Fill-in the drawing opposite.

Tell the crew:

- Where the extinguishers are and how they work.
- The location of fuel tank valves (under the berths of the starboard and port aft cabins).
- Where the emergency exits are.

### ■ ESSENTIAL PRUDENCE RULES

Never:

- Obstruct access to the emergency exits.
- Obstruct safety controls (fuel valves, gas valves, power switches).
- Obstruct the access to the extinguishers placed in cupboards or lockers.
- Leave the boat unattended when a stove or heater is in use.
- Use gas lamps in the boat.
- Alter any of the boat's systems (electricity, gas or fuel).
- Fill up a tank when an engine is running or a stove or heater is on.
- Smoke while handling fuels.

Make sure that bilges are clean at all times and regularly check that there are no fumes or fuel and gas leaks.

Flammable products should never be stored in the engine compartment.

If non-flammable products are stored in the engine compartment these should be fastened to prevent them from falling on the engines and obstructing access.

### **CAUTION**

Should you replace components of the fire extinction system, only proper components with the same designation or with equivalent technical capacities and fire resistance should be used.

### **DANGER**

Evacuate the area immediately after discharging the product to prevent asphyxia. Ventilate before entering.

### ■ PROCEDURE TO FOLLOW IN THE EVENT OF FIRE

- Stop the engines if they are running.
- Shut off the power supply and the fuel supply.
- Cut off all sources of air on the seat of fire (smother the fire using blankets).
- Hold the extinguisher upright and aim at the heart of the fire.

If fire has started in an engine room:

- Stop the engines if they are running.
- Disconnect the power supply, fuel supply and gas supply if necessary.
- Shut off the air supply using towels to block off the engine air inlets, intakes and outlets.
- Aim the fire extinguisher through the fire extinguisher opening at the rear of the aft cabins.
- Make sure that the fire is completely under control.
- Open the access hatch to the engine room in order to make any possible necessary repairs.

### **DANGER**

Always keep an extinguisher handy in case the fire should start again.

## 9.5 Bilge pumping

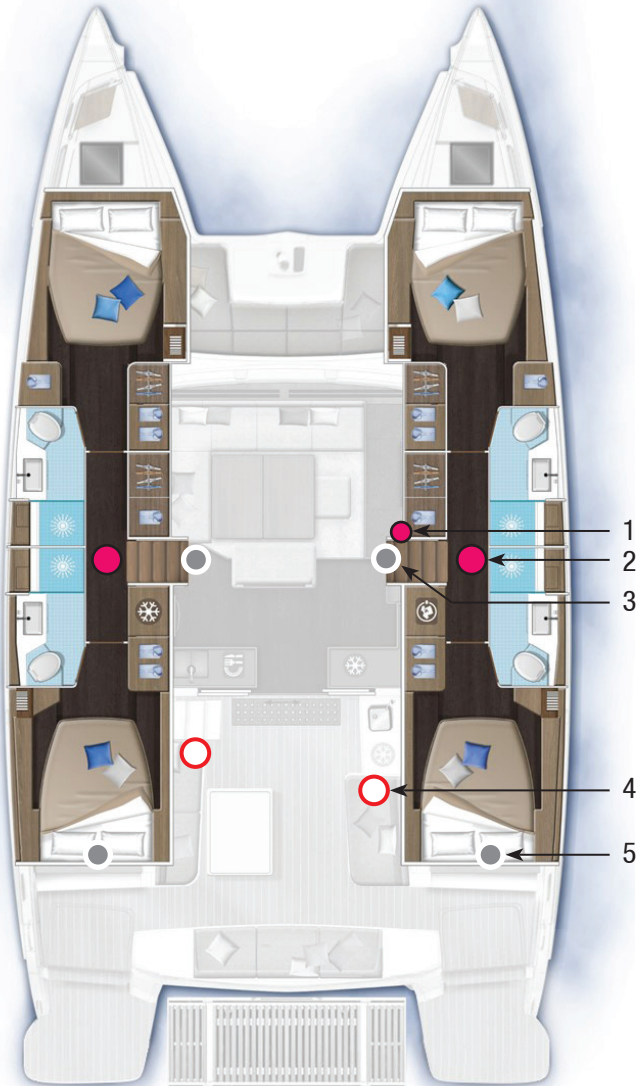

- 1 - Bilge pumps switches.
- 2 - Electric bilge pump.
- 3 - Through-hull drainage electric bilge pumps.
- 4 - Manual bilge pump.
- 5 - Through-hull drainage manual bilge pumps.

### ELECTRIC BILGE PUMP

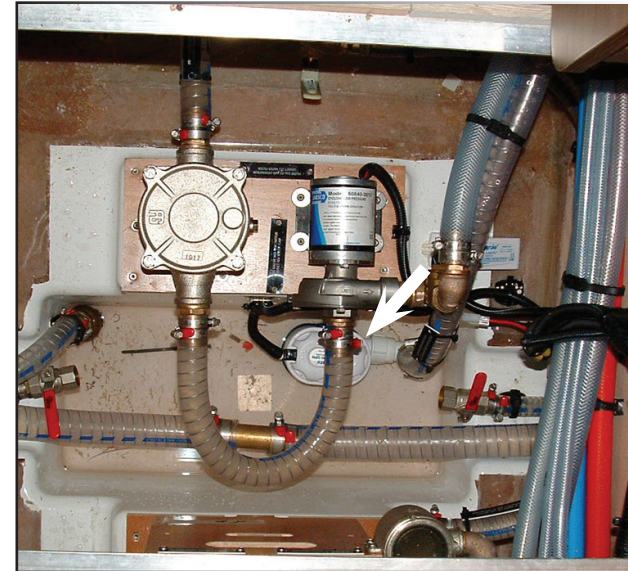

A main sump is located under the floor of each hull. The front and rear compartments are connected to these sumps by a drain and a valve (access under the floors).

#### ■ ELECTRIC BILGE PUMPS

The boat is equipped with an automatically triggered electric bilge pump in the sump (one per hull).

#### **CAUTION**

The bilge pump system is not designed to provide buoyancy to the boat in case of damage.

The bilge pump system is designed to drive out the water being either sea spray or leaks but absolutely not the water coming through a hole in the hull, this hole being the result of a damage.

When the circuit breakers are OFF, the bilge pumps are off and deactivated.

## 9.5 Bilge pumping

**SWITCH PANEL -  
ELECTRIC BILGE PUMPS**

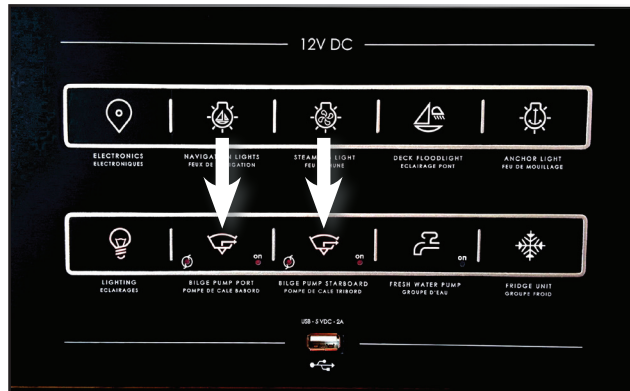

**MANUAL BILGE PUMP**



**MANUAL BILGE PUMP LEVER**



These electric pumps are powered by 12 V.

Manual pumps are activated by the switches on the pump control panel in the cabinet on the side of the chart table.

### **RECOMMENDATION**

Regularly check the valves and sea-cocks for proper operation and watertightness.  
Regularly make sure the filters and strainers on the draining system are clean.

Please note: a valve is closed when its handle is perpendicular to the hose and it is open when its handle is in line with the hose.

### **RECOMMENDATION**

Keep the bilge pumps in the automatic start position with alarm. Carry out a test of the bilge pumps each time before you put out to sea.

### ■ MANUAL BILGE PUMPS

In case of failure or shortfall of the electric bilge pumps, it is possible to use the manual bilge pump.

These pumps are located on the cockpit port and starboard benches. They suck water from the hull sumps.

### ■ PROCEDURE TO FOLLOW IN CASE OF LEAKS

Make sure that the electric bilge pumps are on.

If it is not enough to overcome the water level, ask a crew man to use a manual pump.



# Maintenance

---

# 10

**10.1 Construction**

**10.2 Careening**

**10.3 Deck equipment**

**10.4 Propellers and anodes**

**10.5 Handling**

**10.6 Winter storage**

**10.7 Maintenance schedule**

## 10.1 Construction

### HULL PROTECTION



The Lagoon 51 is constructed following the infusion process of a polyester resin and a high quality anti-osmotic resin on a core of balsa and fibreglass layers.

The hull bottom and keels are made of monolithic laminate by infusion. The hull and the bridge are finished using a gel coat which guarantees a gloss and a high-quality appearance.

#### **RECOMMENDATION**

Do not let the hull's large plexiglass windscreens come into contact with fenders or hawsers: surface damage would be irreparable.

#### **MAINTENANCE**

The materials used to build your boat have been selected for their high quality and performances nevertheless, they require a minimum of maintenance to be protected from exterior elements (salt, sun, chafing, etc.).

To keep her best look, besides her rinsing with fresh water after each trip, you shall polish and shine the gel-coat periodically with cleaning products you will buy at your dealer's.

For possible stubborn stains or scratches, please contact your dealer; he will be delighted to give you the proper advice.

#### **RECOMMENDATION**

Focus on prevention and protection to keep the brand-new aspect of the hull of your boat.

Use the fenders as often as it is necessary; their number and size shall be appropriate.

To prevent the gel coat from getting dirty, cover the fenders.

## 10.2 Careening

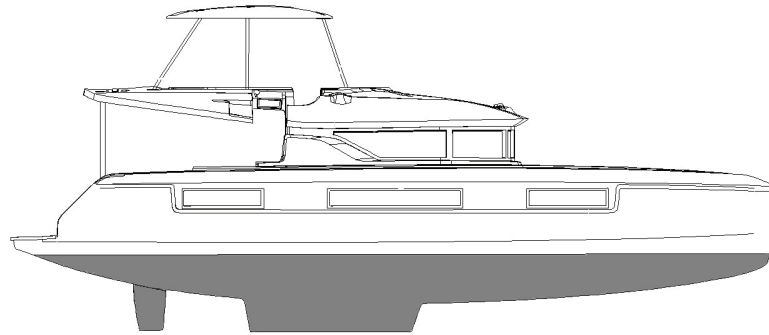

Bottom surface: about 73 m<sup>2</sup>

### ■ CAREENING

A regular careening of the boat maintains its original performance by preventing the adherence of marine vegetation.

The nature of the water in which the boat sails determines the choice of anti-fouling and the careening frequency.

Always consult a professional.

## 10.3 Deck equipment



### ■ PULPITS

Regularly rinse the stainless steel parts with fresh water.

### ■ LIFELINES

Inspect the metallic lifelines for "hairy wires".  
Check for corrosion, particularly on the connections.

### ■ OUTSIDE WOODWORK

Regularly rinse and brush the outside woodworks with fresh water.  
There are teak cleaners products on sale.  
We advise you against using a pressure washer on teak.

## 10.4 Propellers and anodes

FOLDABLE PROPELLER



FIXED PROPELLER



ANODE

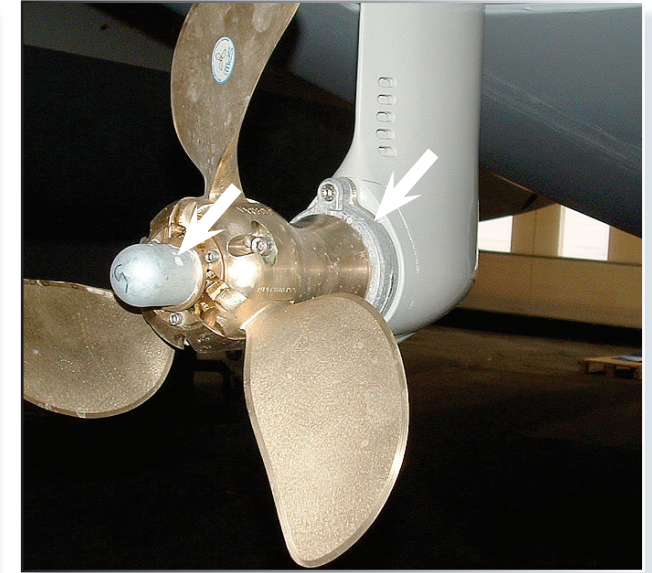

### ■ PROPELLERS

The propellers supplied with your boat are the result of tests carried out jointly with the engine manufacturer.

Do not change them without consulting a specialist.

### ■ ANODES

Periodically check the corrosion of the anode, at least twice a year.

The wear of the anodes depends on numerous factors and their lives may highly vary.

Change them when necessary.

Never paint an anode.

Ask a professional to check and maintain the whole propulsion system.

## 10.5 Winter storage

### ■ LAYING UP

- Take ashore all the ship's log, the ropes that are not used for mooring her, the galley equipment, supplies, clothes, the safety equipment.
- Check the expiry dates of the safety equipment.
- Have the liferaft overhauled.

Take advantage of this laying up to draw up a complete inventory of the equipment.

### ■ ENGINES

The engines winterisation shall be carried out by a professional.

Depending on the boat location, afloat or ashore, winterisation is different.

### ■ WATER CIRCUIT

- Drain the fresh water system.

Let water run from the taps until the system runs dry.

Check that there is no water left in the pipes and hoses (possible low points).

- Take off the filters, remove the water.

Clean the filters if necessary then put them back.

- Drain the water heaters.

Check that there is no water left.

Close the drain.

- Lubricate all the water inlet valves and sea cock fittings.
- Rinse and drain toilet bowls and black water tanks.

### ■ INSIDE

- Seal air inlets as much as you can.
- Install an air dehumidifier in the saloon and leave the cabin and storage unit doors open (stowage cupboards, ice boxes).
- Leave deck hatch dorades in the open position to prevent condensation, mould and rusting.
- Leave the cushions outside for long before putting them back into the boat in the upright and side position in order to have minimum contact surface.
- Drain and clean the bilges.
- Possibly place the floorboards in a vertical position to make possible the ventilation of the different compartments.
- Open the refrigerator / freezer and ice maker doors.

### ■ OUTSIDE

- Carefully drain the cockpit shower.
- Thoroughly rinse the hull and deck.
- Lubricate all the mechanical and mobile parts with vaseline (bolts, hinges, locks, etc.).
- Protect all ropes and mooring lines against chafing.
- Protect the boat to the highest degree with fenders.
- Make sure the boat is properly moored.

#### **RECOMMENDATION**

All these recommendations do not make up an exhaustive list. Your dealer will give you the advice you need and will carry out the technical maintenance of your boat.

## 10.6 Handling

### POSITIONING OF HOISTING STRAPS

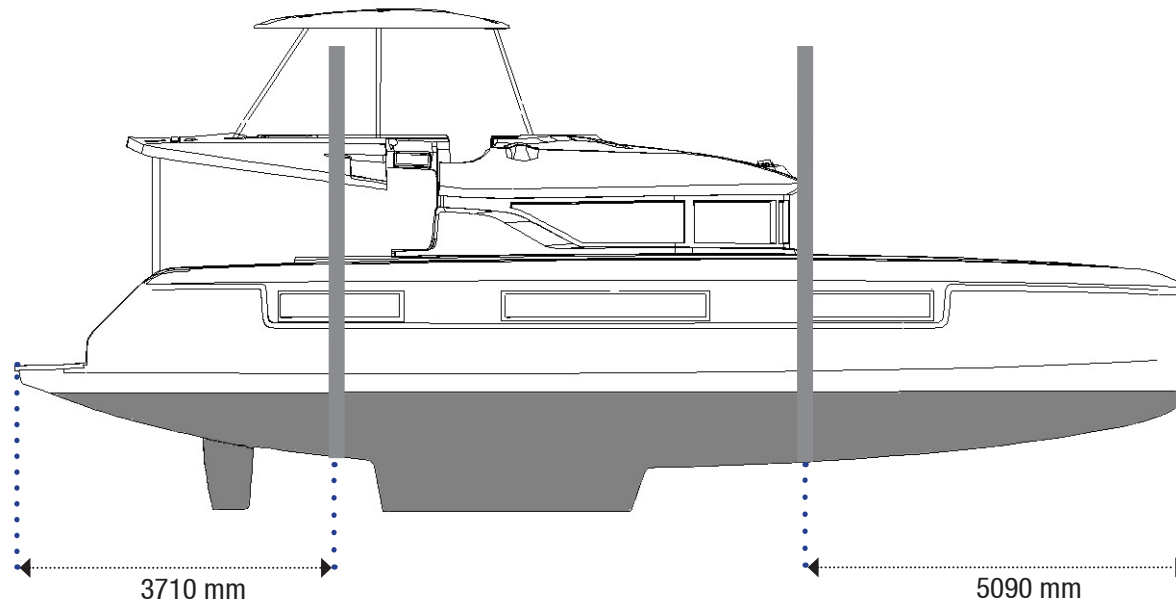

#### **RECOMMENDATION**

Lengths of straps:

Aft: 17.30 m + 30 m.

Fore: 16.86 m + 30 m.

Refer to the CE manual.

## 10.6 Handling

### ■ PREPARATION

The initial launching and the first tests of the different equipments shall be carried out by your dealer so that you can expect to enjoy the warranty in case of some equipment failure.

All further handling shall be carried out with the highest care by professionals. If the LAGOON boatyard is not in charge of operations, they cannot guarantee against any possible accidents linked to handling.

If later you have to launch your boat yourself, you should take the following precautions:

- Retract the sensors under the hull into their housings (they may be damaged by the handling slings).
- Check the water suction boxes for cleanliness.
- Turn off all the water inlet and drain valves (sinks, wash basins, toilets, engines, etc).
- Check that the anodes and grounding plates are in good condition and properly installed.

An anode or a grounding plate must never be painted.

### ■ CRANE LIFTING

- Install a bow mooring rope, a stern mooring rope and fender.
- When lifting with the crane, ensure that the slings are not over any device (sounder, speedometer, etc.), nor over the propellers.

Position the slings according to the symbols on the hull.

The crane hook will be fitted with a gantry or a spreader system with two slings.

The slings shall not be connected directly onto the hook, as it would result in unusual compressive stresses on the hull.

- Crane lifting should be carried out slowly.
- Control the movement of the boat using mooring ropes.

### **DANGER**

Do not stay on board or under the boat during craning.

All handling shall be done with a travel lift.

Contact a professional in crane lifting and travel-lift handling in a marina.

## 10.7 Maintenance schedule

### ■ SUMMARY TABLE

The information given hereafter are only examples and it is not an exhaustive list. They must be adapted, depending on the use of your boat.

#### **CAUTION**

Follow without fail the recommendations given in the instruction guides by the manufacturers of the components added to your boat.

#### DECK / DECK EQUIPMENT / HULL

Clean the hull with appropriate products.....	QUARTERLY
Clean stainless steel parts .....	QUARTERLY
Check the watertightness of the sea-cock fittings.....	BIANNUAL
Clean the seacock fittings and strainers from the outside.....	BIANNUAL
Dismount, clean and lubricate capstans .....	ANNUAL

#### ANCHORING / WINDLASS

Rinse with fresh water the anchor line and anchor box.....	AFTER USE
Check the gypsy and attachment of the anchor/ chain link .....	BIANNUAL
Check brake/blocking system .....	QUARTERLY
Check mooring lines and fenders.....	BIANNUAL
Check electrical connections (controls, relays, etc.).....	QUARTERLY

#### UPHOLSTERY AND PROTECTION COVERS

Rinse / clean the various covers.....	QUARTERLY
Dry the outside upholstery before storage.....	AFTER USE

## 10.7 Maintenance schedule

### REFRIGERATION UNIT

Defrost refrigerators, freezers and icemaker .....QUARTERLY  
Check the door joints .....QUARTERLY

### AIR CONDITIONING

Check the sea cocks and clean / change  
the various sea water filters .....QUARTERLY  
Dust off the unit heater fans .....ANNUAL

### ELECTRICITY

Check and tighten the battery terminal  
connections and main switch connections .....BIANNUAL  
Check and tighten the battery terminal connections  
and main switch connections (winches, windlass, etc.) .....BIANNUAL

### WATERMAKER

Check and clean the sea water  
suction filters ..... MONTHLY  
General inspection by the manufacturer ..... ANNUAL

### PLUMBING

Check the automatic bilge pumps  
and alarms .....QUARTERLY  
Check manual bilge pump .....QUARTERLY  
Rinse black water holding tanks .....QUARTERLY  
Rinse grey water collectors .....QUARTERLY  
Check pressurised water unit .....QUARTERLY  
Check various drains and scuppers .....QUARTERLY  
Operate various valves on board  
+ lubrication if necessary .....BIANNUAL

### ENGINES AND GENERATOR

Check oil level .....QUARTERLY  
Check belt tensions .....QUARTERLY  
Clean sea water filters .....QUARTERLY  
Check for leaks (oil, water, fuel) and smoke .....QUARTERLY  
Check and drain the decanter filters (fuel) .....QUARTERLY  
General overhaul ..... REFER TO THE MANUFACTURER'S GUIDE



# GENERAL SPECIFICATIONS

---

11

- 11.1 Technical specifications**
- 11.2 Engine layout**
- 11.3 Plumbing layout**
- 11.4 Electricity layout**
- 11.5 Overview of 12 V elements**
- 11.6 Overview of 110 V / 220 V elements**
- 11.7 Control touch screen - Function overview**

## 11.1 Technical specifications

### ■ TECHNICAL SPECIFICATIONS

Overall length .....	15,35 m (50'4")
Waterline length.....	14,31m (46'1")
Midship beam.....	8,10 m (26'7")
Keel draft.....	1,50 m (4'11")
Max air draft.....	27,2 m (89')

Theoretical light displacement .....	19697 kg (43432 lbs)
Theoretic fully laden displacement.....	29014 kg (63976 lbs)

Maximum fully laden displacement (cat. A) .....	28194 kg / 62168 lbs
Maximum fully laden displacement (cat. B) .....	28194 kg / 62168 lbs
Maximum fully laden displacement (cat. C) .....	28194 kg / 62168 lbs
Maximum fully laden displacement (cat. D) .....	29014 kg / 63976 lbs
Maximum load (cat. A) .....	2360 kg / 5204 lbs
Maximum load (cat. B) .....	2360 kg / 5204 lbs
Maximum load (cat. C) .....	2360 kg / 5204 lbs
Maximum load (cat. D).....	3180 kg / 7012 lbs

Fuel capacity (standard).....	2 X 520 l (2 x 137,37 US Gal)
Black water capacity .....	240 l (63,4 US Gal) 3 Head compartments
	310 l (81.9 US Gal) 4 Head compartments
Freshwater capacity .....	2 x 240 l (2 x 63,40 US Gal)
	+ 2 x 175 l (2 x 46 US Gal)

Positive cold capacity .....	190 l (50,2 US Gal)
Negative cold capacity .....	90 l (24 US Gal)
Cockpit cold capacity .....	80 l (21 US Gal)

### 12 V BATTERY CAPACITY

Auxiliary .....	3 x 140 Ah
Auxiliary (option) .....	6 x 140 Ah
Engines .....	110 Ah each
Generator .....	1 x 50 Ah

### ■ MOTORIZATION

Engine power.....	2 x 80 CV / HP
-------------------	----------------

# 11.1 Technical specifications

## ■ DESIGN CATEGORY

Design category..... A

## CE CATEGORY

Maximum number of persons

- A..... 14 persons
- B ..... 14 persons
- C ..... 16 persons
- D ..... 30 persons

Design categories weather conditions				
Categories	Max wind			Max waves
A	Force 9	Established at 47 knots	Gusts of approx. 61 knots	10 m
B	Force 8	Established at 40 knots	Gusts of approx. 52 knots	8 m
C	Force 6	Established at 27 knots	Gusts of approx. 35 knots	4 m
D	Force 4	Established at 16 knots	Gusts of approx. 23 knots	0.5 m

Note:  
 . The wind force (Beaufort scale) is the average actual wind speed over a period of 10 minutes at 10 metres above the sea.  
 . The maximum height of waves is measured from trough to crest. European regulations use the concept of significant wave height (H: 1/3).

Architects .....VPLP Design

Design .....Nauta Design

## ■ MISCELLANEOUS EQUIPMENT

Max load on tenderlift ..... 250 kg

Max tender dimensions..... 3,40 m

Electric windlass power ..... 2.000 W

Generator power ..... 11 Kva at 220 V - 50 Hz

Max. generator power ..... 13.5 Kva en 110 V - 60 Hz

Air-conditioning capacity ..... 64000 BTU

## ■ INTERIORS

Cabins ..... 4 / 5 / 6

Berths..... 8 / 10 / 12

### Best headroom:

Carré ..... 2.06 m (6'9")

Cabins ..... 1.92 m (6'9")

Head compartments ..... 1.97 m (6'6")

## 11.2 Engine layout

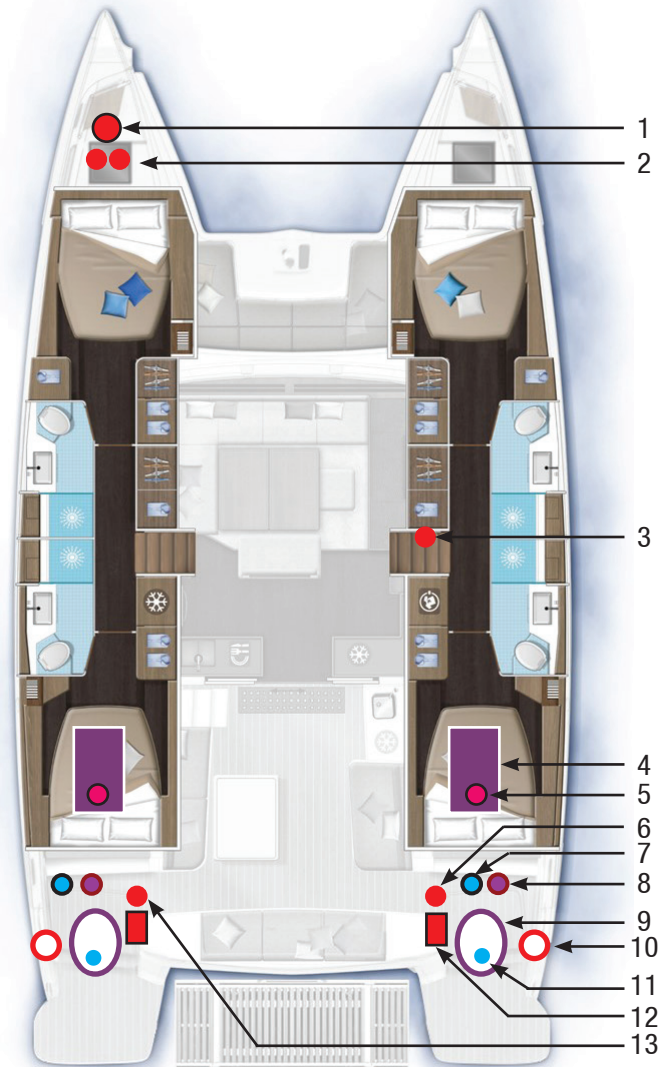

- 1 - Bow thruster.
- 2 - Bow thruster batteries.
- 3 - Fuel gauge.
- 4 - Fuel tank.
- 5 - Fuel valve.
- 6 - Starboard and on-board engine battery cut-out switches.
- 7 - Sea water filter.
- 8 - Fuel filter.
- 9 - Engine.
- 10 - Deck filler.
- 11 - Engine water inlet valve.
- 12 - 12 V battery.
- 13 - Port engine battery and coupling cut-out.

## 11.3 Plumbing layout

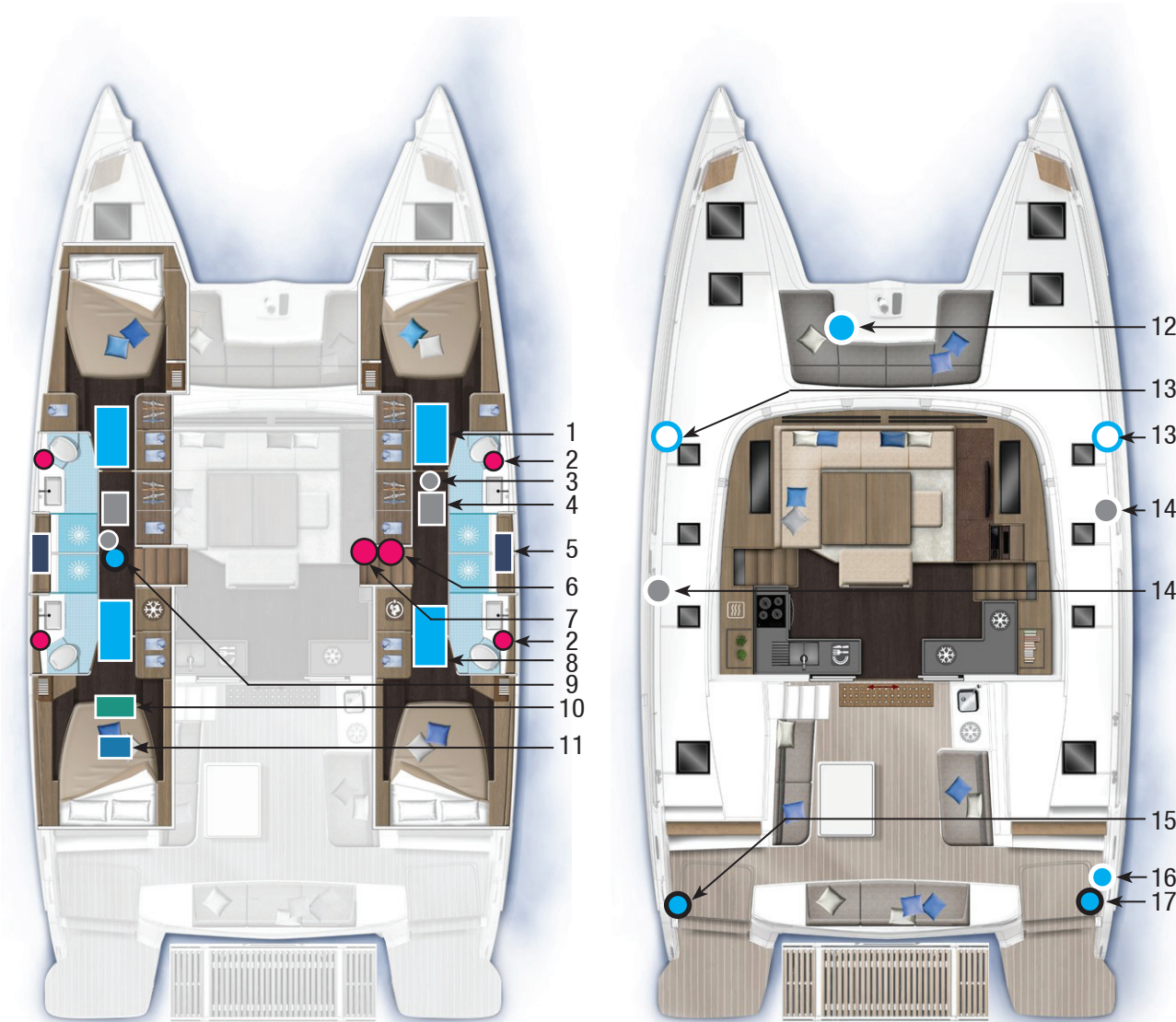

- 1 - Fresh water tank 175 l.
- 2 - WC electric pump.
- 3 - Overboard discharge valve for black water.
- 4 - Grey water holding tank (option).
- 5 - Black water tank.
- 6 - Fresh water and grey water tank gauges (option)  
+ grey water sea drain switches.
- 7 - Operation of the freshwater unit.
- 8 - Fresh water tank (240 l).
- 9 - Pressure water pump.
- 10 - Watermaker.
- 11 - Water heater.
- 12 - Deck wash pump connection.
- 13 - Fresh water deck filler.
- 14 - Black water drain fitting.
- 15 - Cockpit shower (option).
- 16 - Shore fresh water supply.
- 17 - Cockpit shower (standard).

## 11.4 Electricity layout

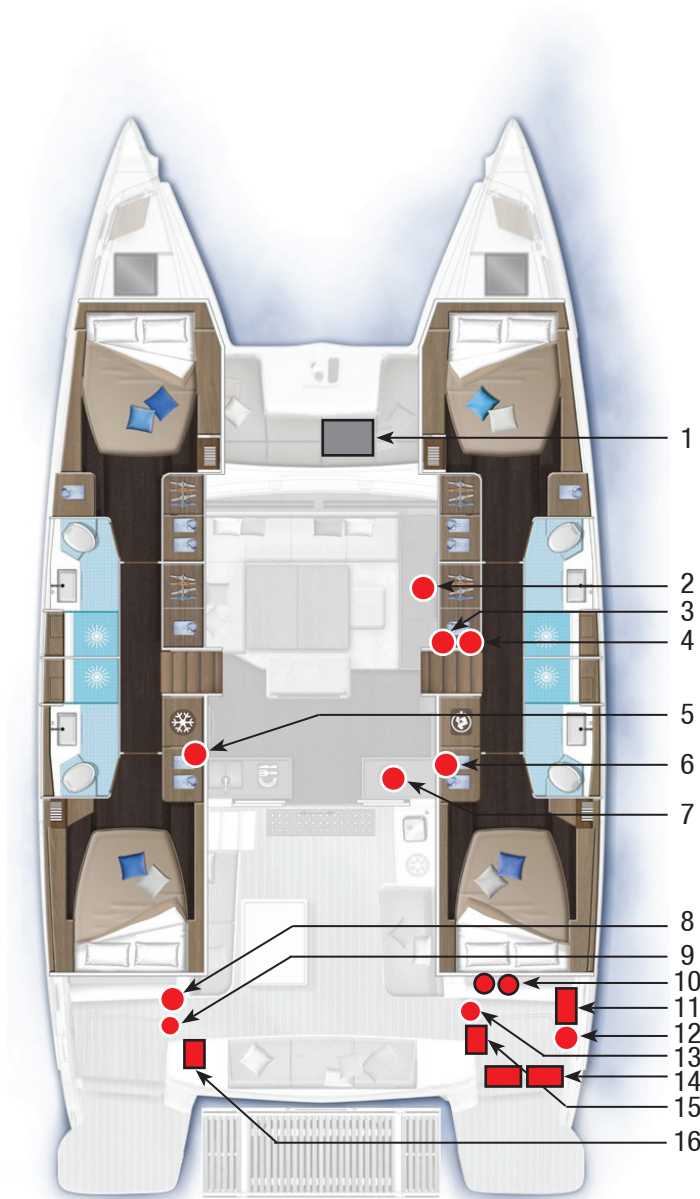

- 1 - Generator (see details on page 84).
- 2 - Saloon fuses.
- 3 - 12 V electrical panel
- 4 - 220 V electrical panel, on-board circuit breakers,  
12 V / 220 V - 2000 VA inverter.
- 5 - Port hull fuses.
- 6 - Starboard hull fuses.
- 7 - Roof fuses.
- 8 - Air conditioning components circuit breakers.
- 9 - Port engine battery and coupling cut-out.
- 10 - 12 V battery chargers (on-board).
- 11 - On-board battery bank.
- 12 - Shore power socket circuit breakers.
- 13 - Starboard and on-board engine battery switch.
- 14 - On-board battery banks.
- 15 - Starboard engine starter battery.
- 16 - Port engine starter battery.

## 11.5 Overview of 12 V elements

### ELECTRIC CHARGE AND CONVERSION

1 x 220 V / 12 V - 60 A charger	Engines + on-board
1 x 220 V / 12 V - 40 A (option)	Engines + on-board
2 x 12 V - 80 A alternators	Charge service bank, engine batteries, generator

### BATTERIES / ELECTRICAL CONSUMERS

12 V SUPPLY	VOLTAGE	START (+ PROTECTION)	PROTECTION
Service batteries	12 V - 140 Ah (standard)		
Navigation electronics	12 V	12 V electrical panel	
Navigation electronics	12 V	12 V electrical panel	
Navigation lights	12 V	12 V electrical panel	
Fridges, freezer	12 V	12 V electrical panel	
Water unit	12 V	12 V electrical panel	
Electric toilets	12 V	12 V electrical panel	
Deck wash pump	12 V	12 V electrical panel	
Bilge pumps	12 V	12 V electrical panel	
Winches	12 V	12 V on-board	Roof starboard
Windlass	12 V	12 V on-board	Service room
Watermaker	12 V	12 V on-board	Port gangway
VHF	12 V	12 V on-board	Terminal block 12 V
Hifi	12 V	12 V on-board	Terminal block 12 V
Autoradio	12 V	12 V on-board	Terminal block 12 V
Power sockets 12 V	12 V	12 V on-board	Terminal block 12 V
Engine batteries (x2)	12 V - 110 Ah		
Generator battery	12 V - 50 Ah		
On-board batteries	12 V - 140 Ah		

## 11.6 Overview of 110 V / 220 V elements

### GENERATOR

Power 11 Kva at 220 V  
Power 13.5 Kva at 110 V

100% of charge at 220 V - 50 Hz  
100% of charge at 110 V - 60 Hz

### SHORE POWER SOCKETS

On-board shore power socket 220 V - 50 Hz  
Air conditioning shore power socket 220 V - 50 Hz

32 A Single shore power socket Starboard aft transom connection  
32 A Single shore power socket Starboard aft transom connection

On-board shore power socket 110 V - 60 Hz (US version)  
Air conditioning shore power socket 110 V - 60 Hz (US version)

50 A Single shore power socket Starboard aft transom connection  
50 A Single shore power socket Starboard aft transom connection

### ELECTRICAL DISTRIBUTION

Left selector  
Right selector

Boat powered by generator or from shore (or 12 V / 220V - 2000Va inverter)  
Air conditioning powered by generator or from shore

### LOAD

1 x 220 V / 12 V - 60 A charger  
1 x 220 V / 12 V - 40 A charger

Charge service bank from the generator or shore  
Charge service bank from the generator or shore

220 V / 12 V - 25 A charger

With optional generator to recharge the generator 12 V battery

## 11.6 Overview of 110 V / 220 V elements

ELECTRIC CONSUMERS	OPERATING VOLTAGE	220 V BOAT OPERATING VOLTAGE	110 V BOAT OPERATING VOLTAGE
Piezo-electric gas hob and oven	220 V	Standard inverter	Standard inverter
Hifi	220 V	Optional inverter	Optional inverter
Power sockets	220 V or 110 V	Comfort Busbar	Comfort Busbar
Icemaker	220 V or 110 V	Comfort Busbar	Comfort Busbar
Microwave oven	220 V or 110 V	Comfort Busbar	Comfort Busbar
Televisions	220 V	Comfort Busbar	Comfort Busbar
Washing machine	220 V or 110 V	Power Busbar	Comfort Busbar
Dishwasher	220 V or 110 V	Power Busbar	Comfort Busbar
Water heater	220 V	Power Busbar	220 V Power and engine busbar
Watermaker	220 V	Power Busbar	Power Busbar
Air conditioning	220 V	Air conditioning busbar	220 V air conditioning busbar (dual phase)

### SHORE CONNECTION DIAGRAM 50 A - 115 V FOR A US VERSION BOAT

The boat is equipped with an on-board 50 A 2P+G socket (P1+P2+N+G) for the Air conditioning circuit.

The supplied power cable is a 3610 mm<sup>2</sup> cable with:

On board: a 50 A 2P + G socket

Dock side: a 50 A 2P + G plug

A 50 A bipolar differential circuit breaker is placed on the line in the existing unit.

The on board circuit is connected to the one phase at the output of the 50 A circuit breaker.

The shore neutral is connected to the on-board neutral.

The dock earth is connected to the on board earth via a galvanic isolator.

## 11.6 Overview of 110 V / 220 V elements

### 220 V 50hz ELECTRICAL CIRCUIT - CHARGING SYSTEM

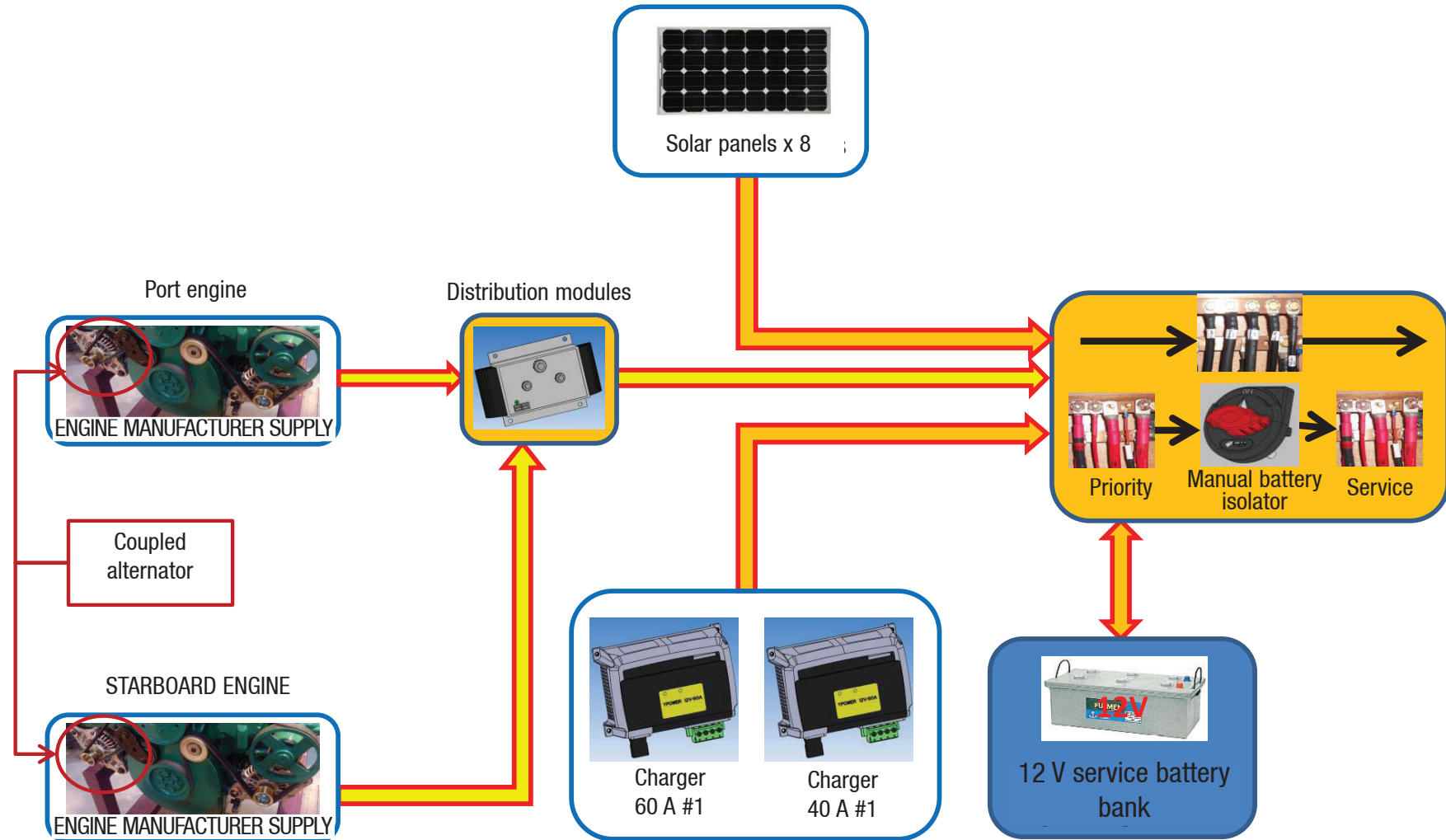

# 11.6 Overview of 110 V / 220 V elements

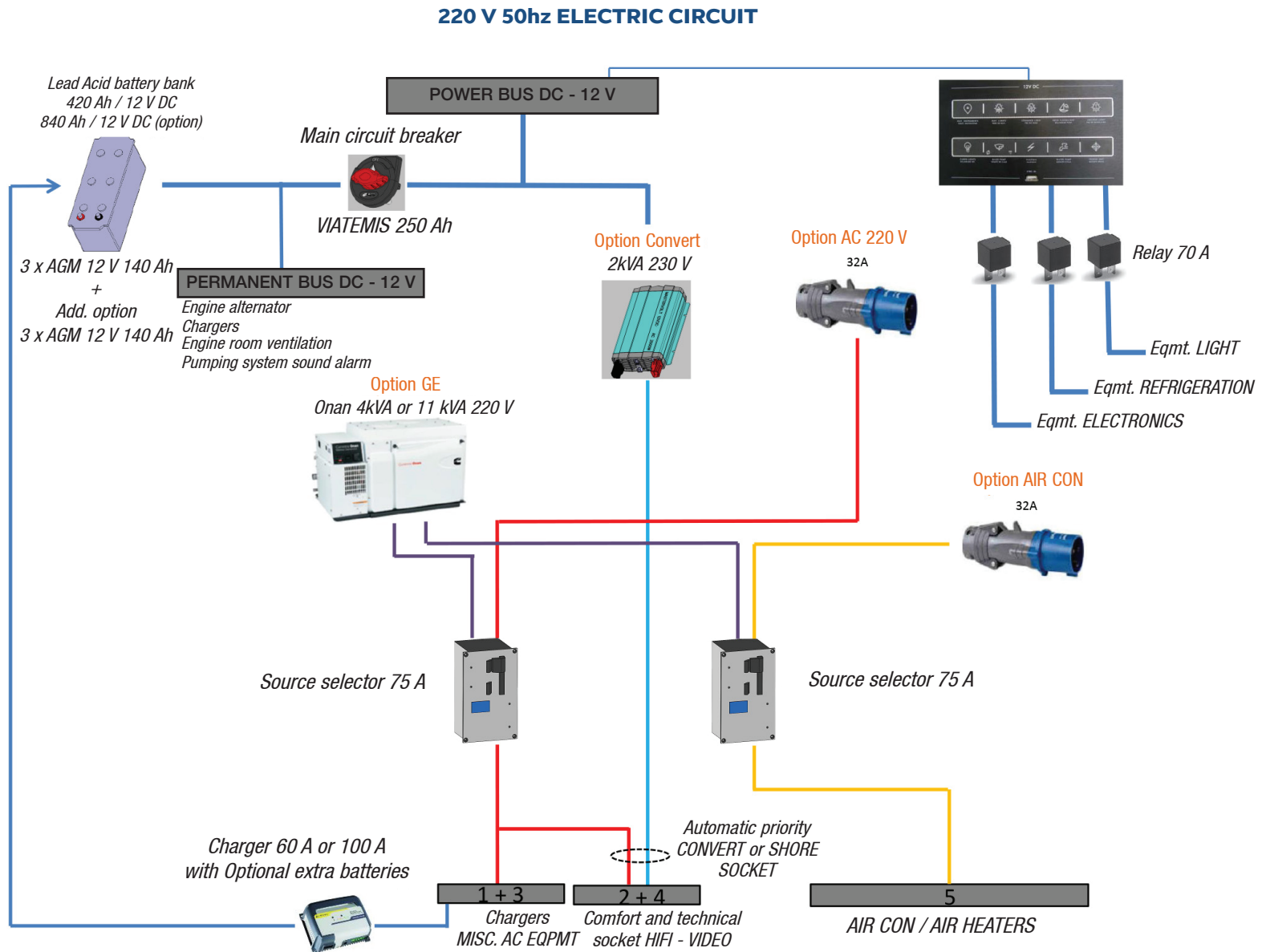

## 11.6 Overview of 110 V / 220 V elements

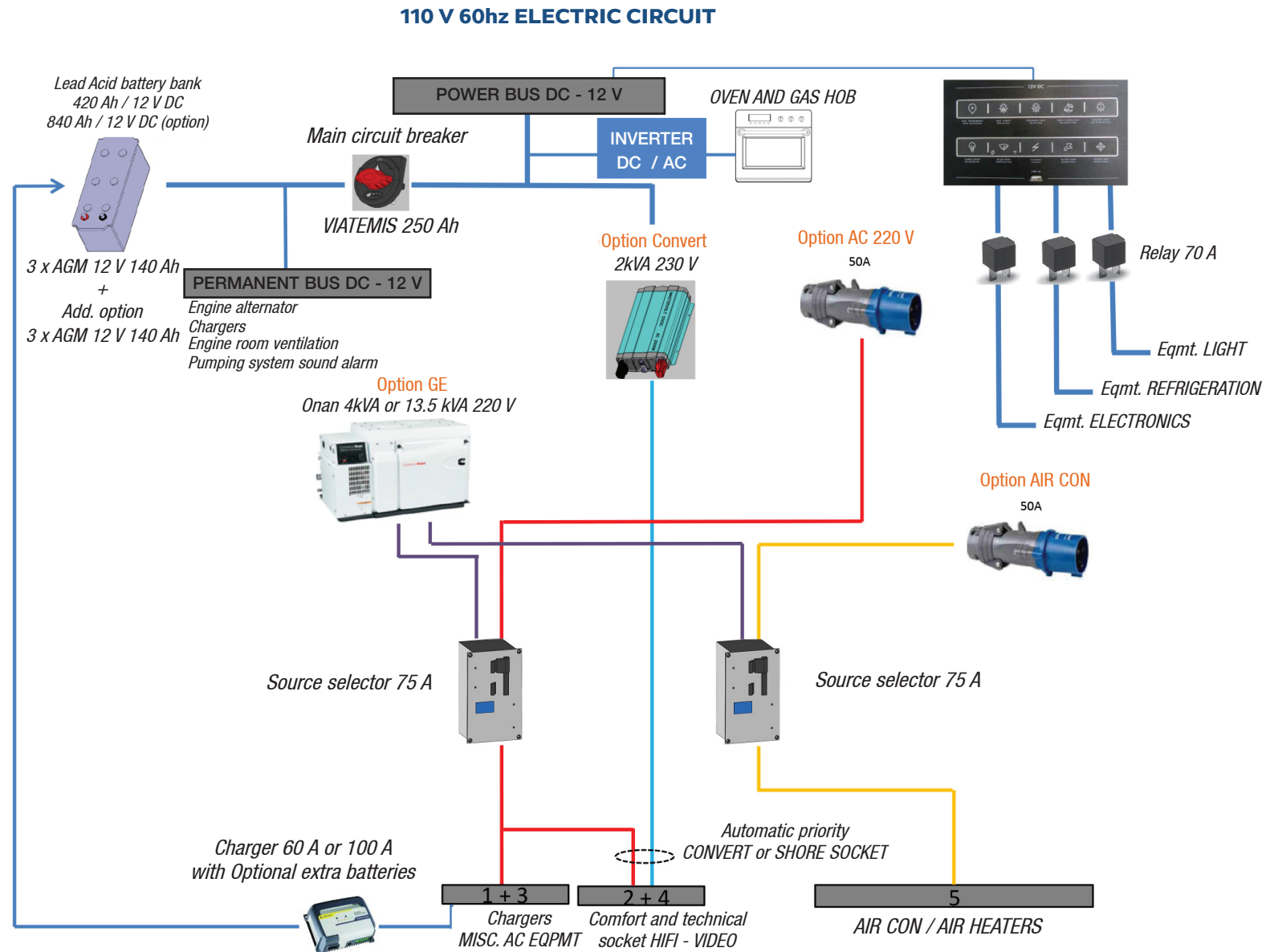

## 11.7 Control touch screen - Function overview

■ CONTROL TOUCH SCREEN:  
One impulse on the icon of the desired menu enables access to the sub menu.

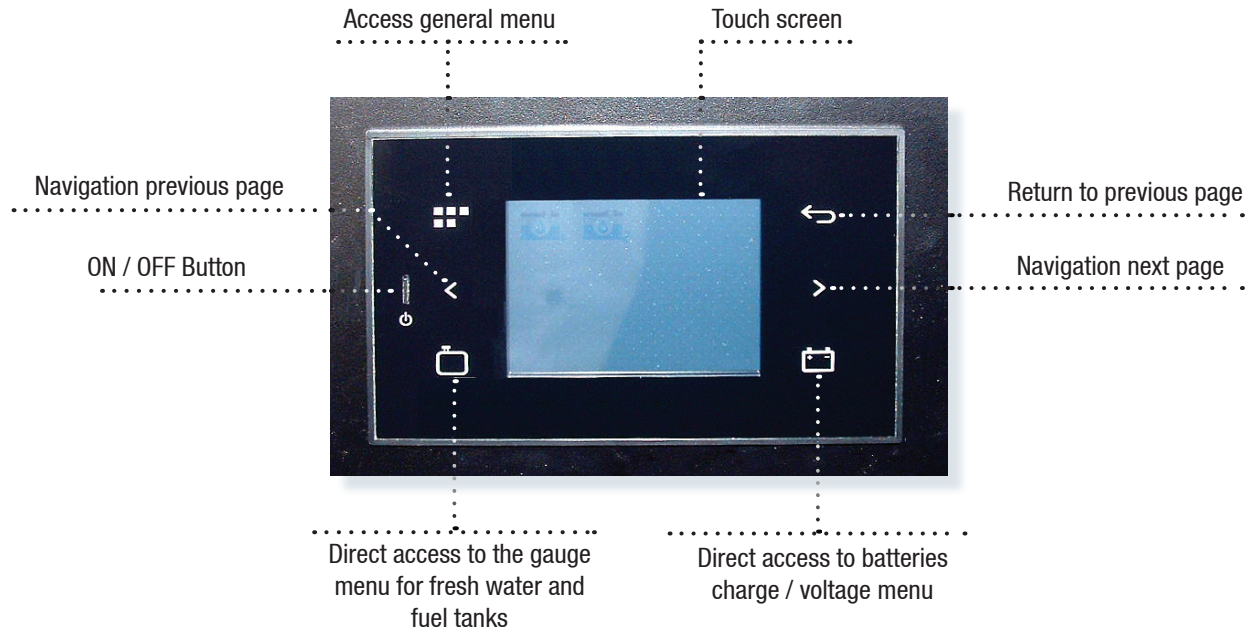

## 11.7 Control touch screen - Function overview

### ■ Menu - MAIN:

This menu provides access to various submenus of the functions controlled from the screen.

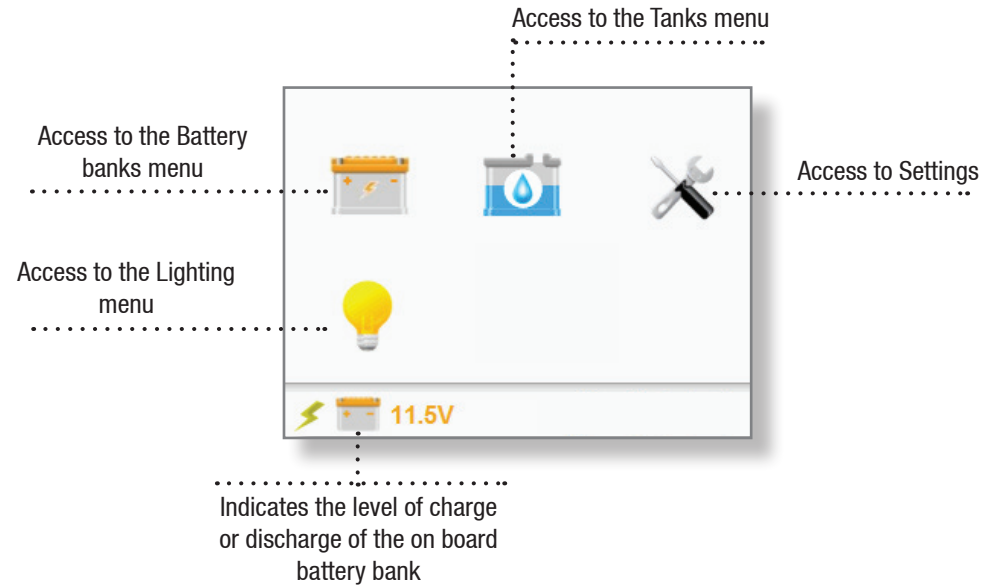

# 11.7 Control touch screen - Function overview

■ Menu – TANKS:  
Enables monitoring of the levels in the tanks  
- freshwater and black water

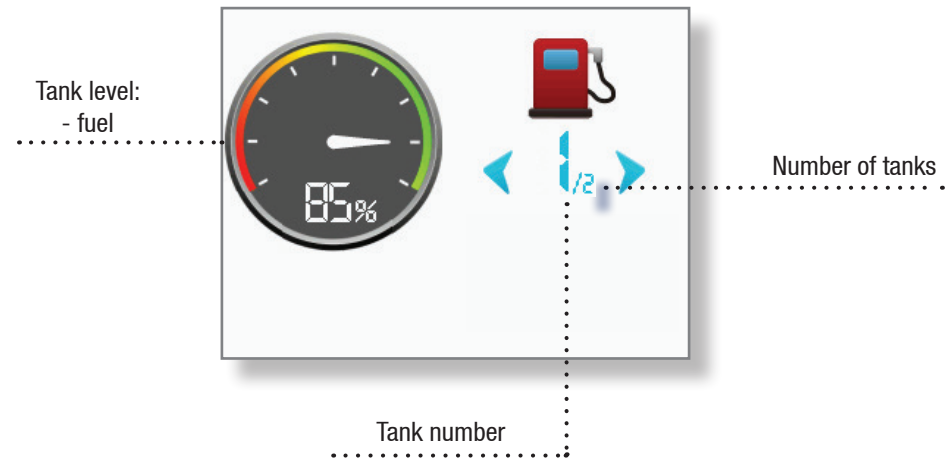
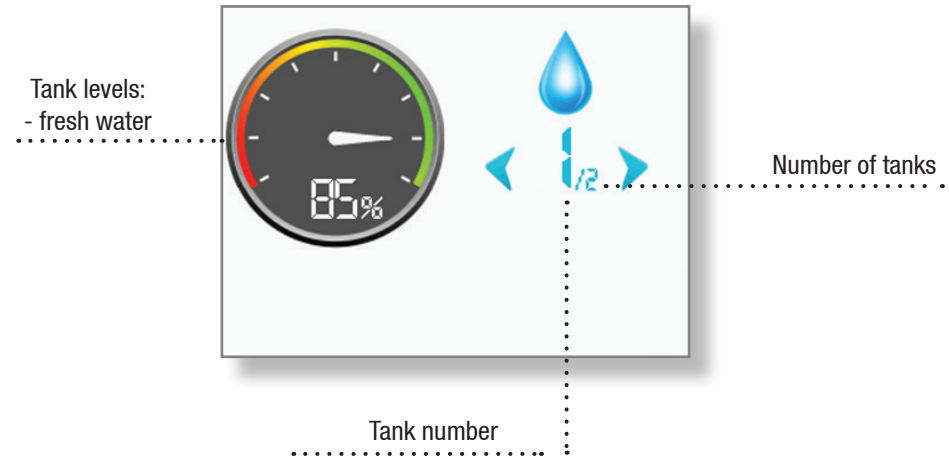
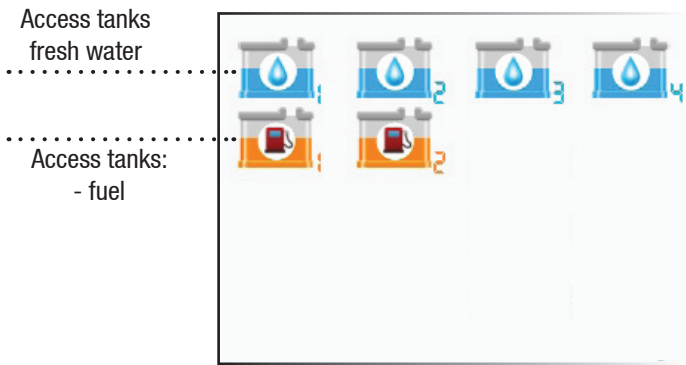

## 11.7 Control touch screen - Function overview

■ Menu – BATTERIES:  
Allows to check the charges of the banks:  
engine batteries, on-board and thruster.

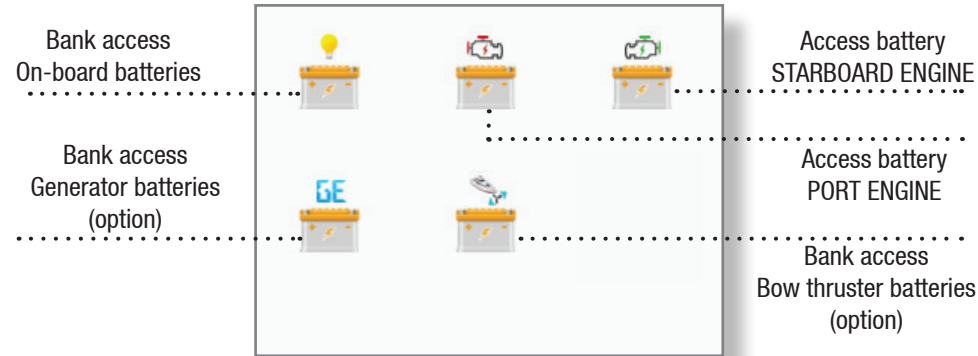

□ Menu – ON BOARD BATTERIES

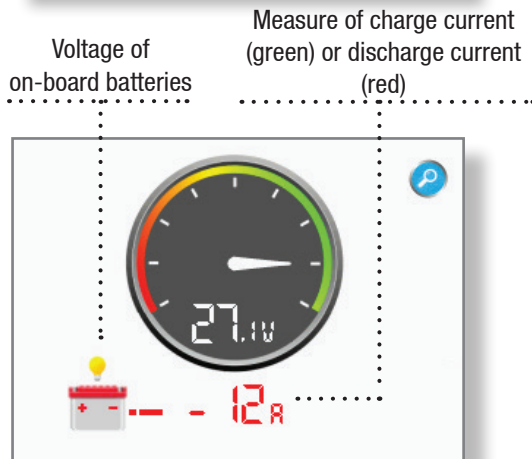

□ Menu – ENGINE BATTERIES

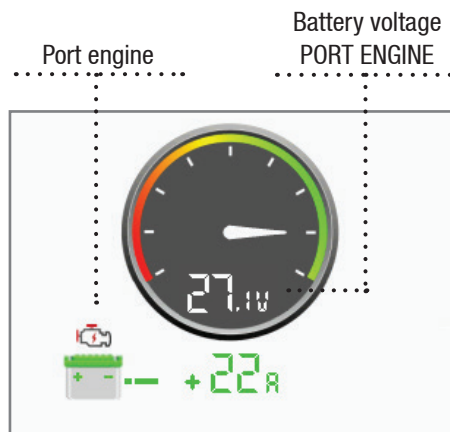

□ Menu – THRUSTER BATTERIES

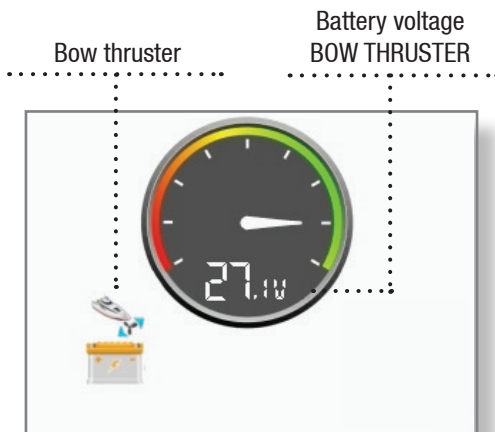

# 11.7 Control touch screen - Function overview

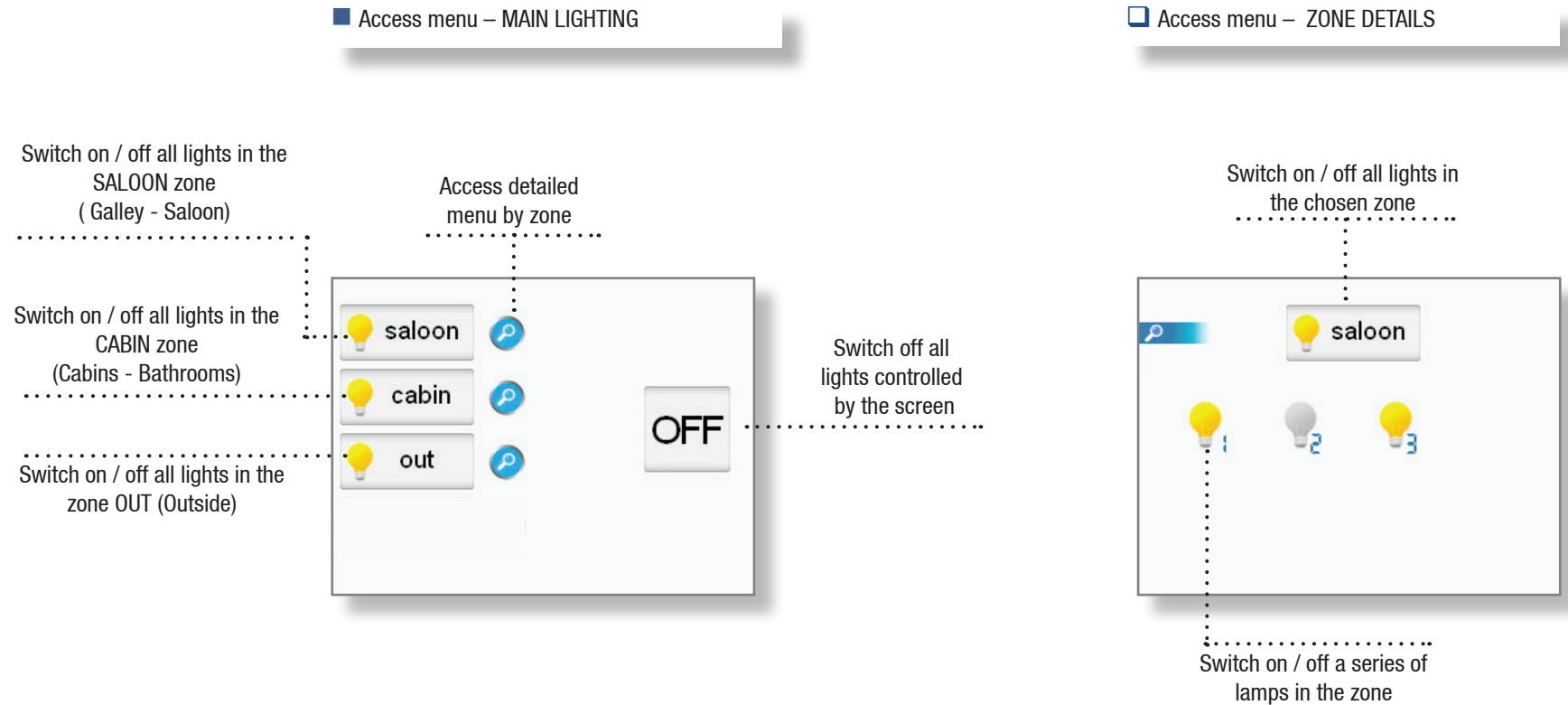



# MEMORANDUM

---

12

**12.1 Your boat**

**12.2 Personal notes**

## 12.1 Your boat

BOAT NAME: .....

VERSION: .....

DELIVERY DATE:.....

REGISTRATION NUMBER: .....

NUMBER OF ENTRANCE KEY: .....

HULL NUMBER .....

MAKE OF THE ENGINES: .....

NUMBER OF ENGINE KEYS: .....

SERIAL NUMBER STARBOARD ENGNE: .....

SERIAL NUMBER PORT ENGNE: .....

ADDITIONAL INFORMATION: .....

.....

.....

OWNER'S NAME: .....

ADDRESS: .....

.....

.....

E-MAIL ADDRESS: .....

LAND LINE: .....

MOBILE PHONE: .....

***PHONE NUMBERS TO CONTACT***











LAGOON

162, quai de Brazza  
CS 81217  
33072 Bordeaux Cedex - France  
Tel. 33 + (0) 557 80 92 80  
E-mail : [info@cata-lagoon.com](mailto:info@cata-lagoon.com)

[www.cata-lagoon.com](http://www.cata-lagoon.com)